

Hurricane Katrina: Perceptions of the Affected

April 21, 2006

Table of Contents

Table of Contents.....	2
Research Objectives.....	3
Detailed Findings.....	4
Evacuation and Recollection During the Storm.....	5
Rescue Operations.....	15
Relief Operations.....	19
Evaluation of Relief Organizations.....	37
Storm Aftermath.....	46
Methodology.....	56
Profile of Survey Participants.....	58

As large-scale disasters have grown in frequency and magnitude, accountability of relief organizations has become a critical area of focus, investigation and public scrutiny/judgment. In order to understand the experiences of relief recipients, Fritz Institute commissioned Harris Interactive to help conduct research that will:

- § Measure perceptions and experiences of aid recipients related to disaster relief across a variety of agencies, geographies and services
- § Offer a combination of traditional and innovative research techniques that will provide objective data that is defensible; publishable to media outlets and the relief sector as a whole; and help contribute to the development of a fair and efficient system of relief that is inclusive of all disaster victim populations.

Detailed Findings

Evacuation and Recollection During the Storm

Reasons Why Those Affected by Katrina Did not Evacuate

Q500: Did you evacuate your home before Hurricane Katrina hit?

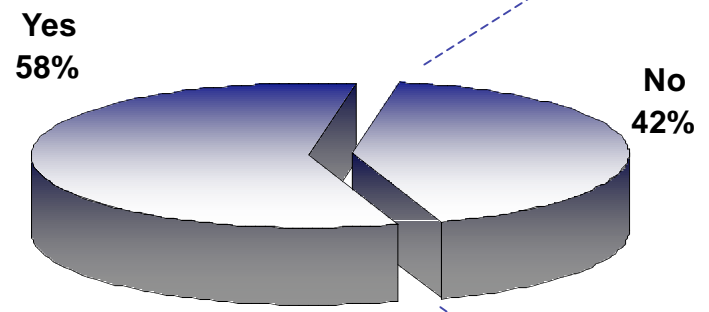

Q505: Why did you not evacuate your home before Hurricane Katrina made landfall?

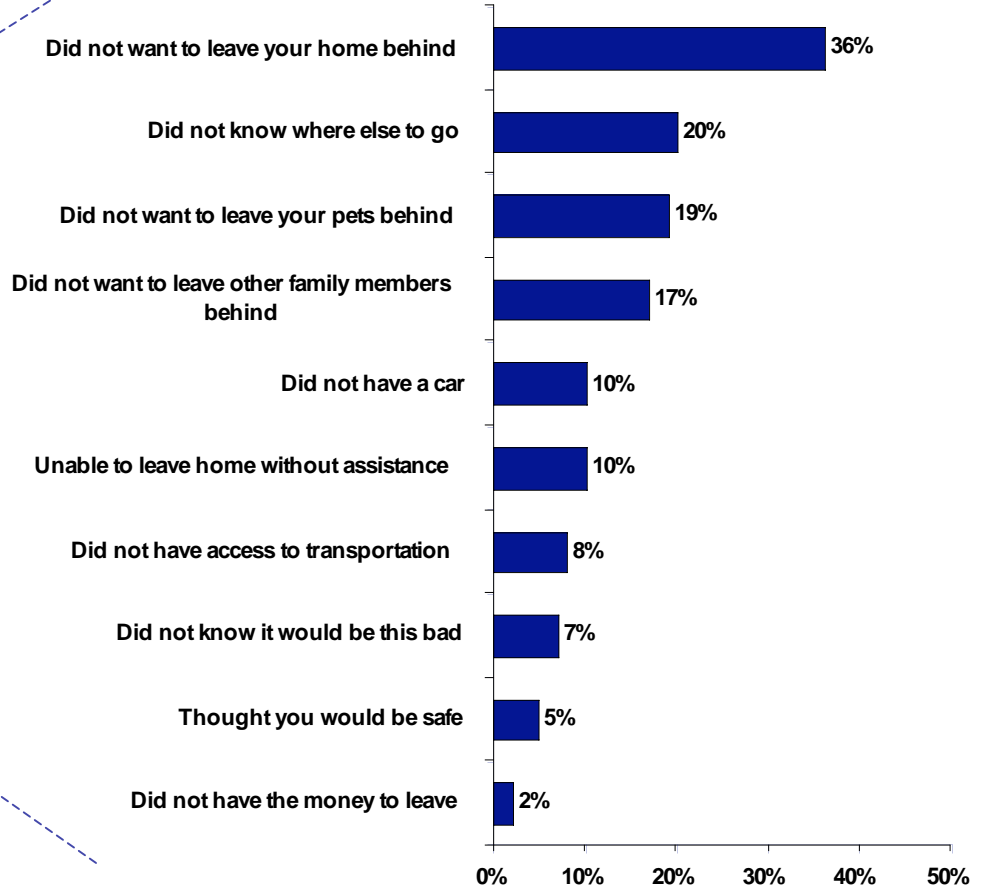

Reasons Why Those Affected by Katrina Did not Evacuate

A Closer Look at Income and Race



Q505: Why did you not evacuate your home before Hurricane Katrina made landfall?

	Income				Race		
	Total	< \$35K	\$35K-\$50K	\$50K+	White	Black	Other
	%	%	%	%	%	%	%
You did not want to leave your home behind	36	32	60	33	40	34	26
You did not know where else to go	20	31	11	12	11	27	38
You did not want to leave your pets behind	19	17	32	17	25	4	17
You did not want to leave other family members behind	17	23	16	1	10	28	24
You did not have a car	10	19	7	1	4	21	18
You were unable to leave home without assistance	10	18	4	1	2	16	25
You did not have access to transportation	8	14	7	2	1	22	16
You did not know it would be this bad	7	11	4	4	2	12	13

BASE: People who did not evacuate (n=430), Less than \$35K (n=187), \$35K-50K (n=62*), \$50K+ (n=141), White (n=277), Black (n=76*), Other (n=72*)

Reasons for Non-evacuation – Choice vs. Means

Q505: Why did you not evacuate your home before Hurricane Katrina made landfall?

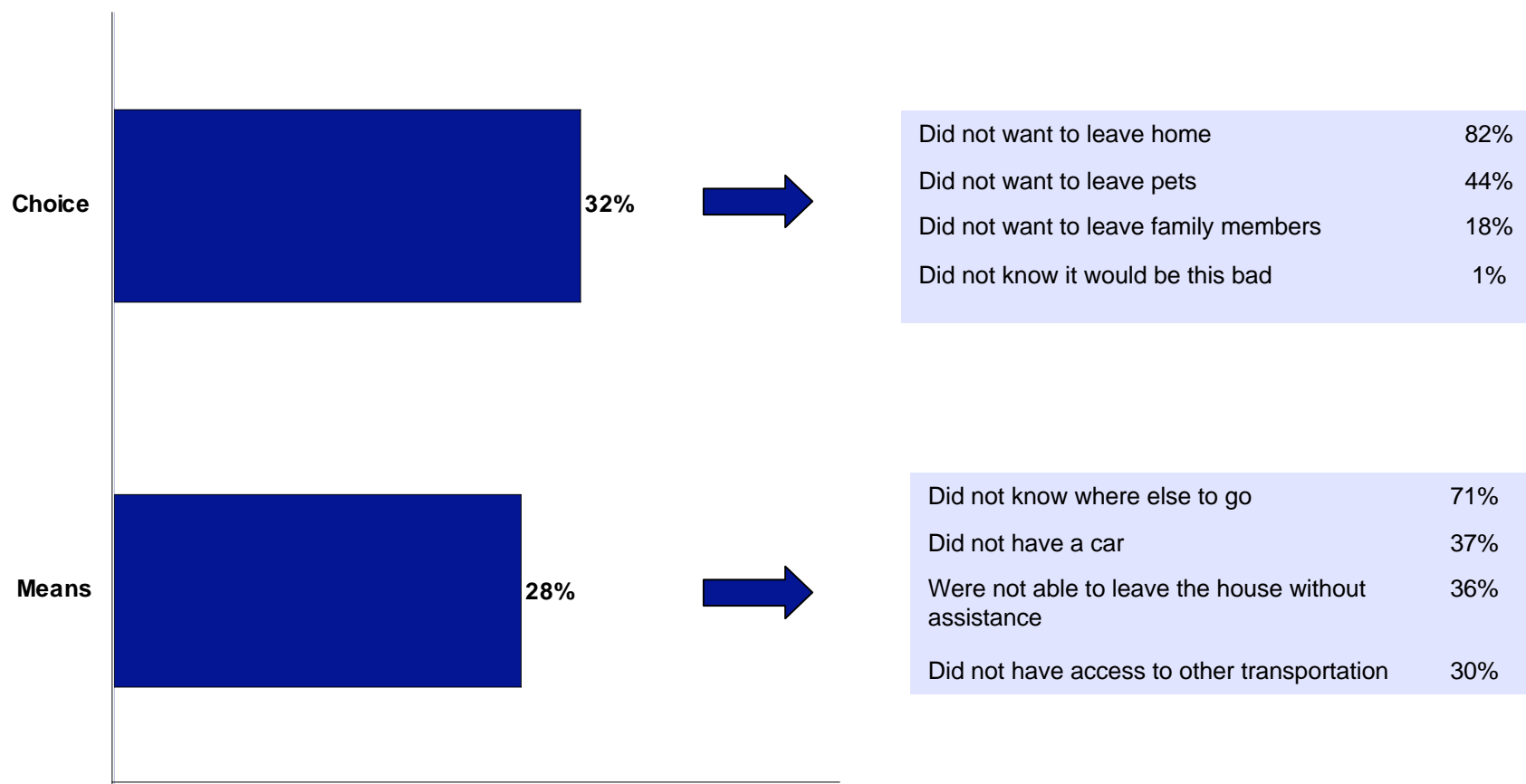

BASE: People who did not evacuate (n=430)

Reasons for Non-evacuation – Choice vs. Means

Q505: Why did you not evacuate your home before Hurricane Katrina made landfall?

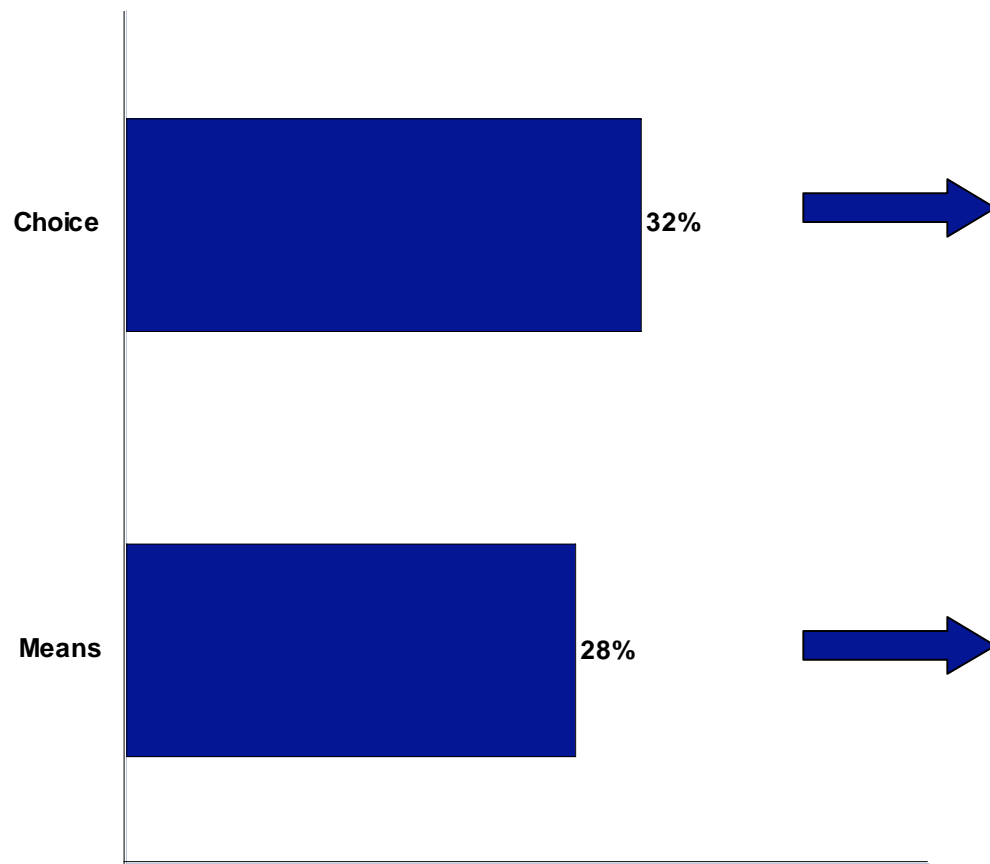

Live in single family homes	84%
Do not have disabilities	83%
White	75%
Do not have children	74%
Employed	67%
Men	62%
Have attended at least some college	61%
Mississippi	56%
Income more than \$50,000	36%
Louisiana	26%
Alabama	18%

Income less than \$50,000	84%
Women	66%
Have children	60%
African American	58%
High school education or less	57%
Not employed	53%
Not married	56%
Louisiana	41%
Mississippi	39%
Have a disability	32%
Alabama	20%

BASE: People who did not evacuate (n=430)

Recollections of Katrina Making Landfall

Q1595: Who were you with when the hurricane hit? Were you...?

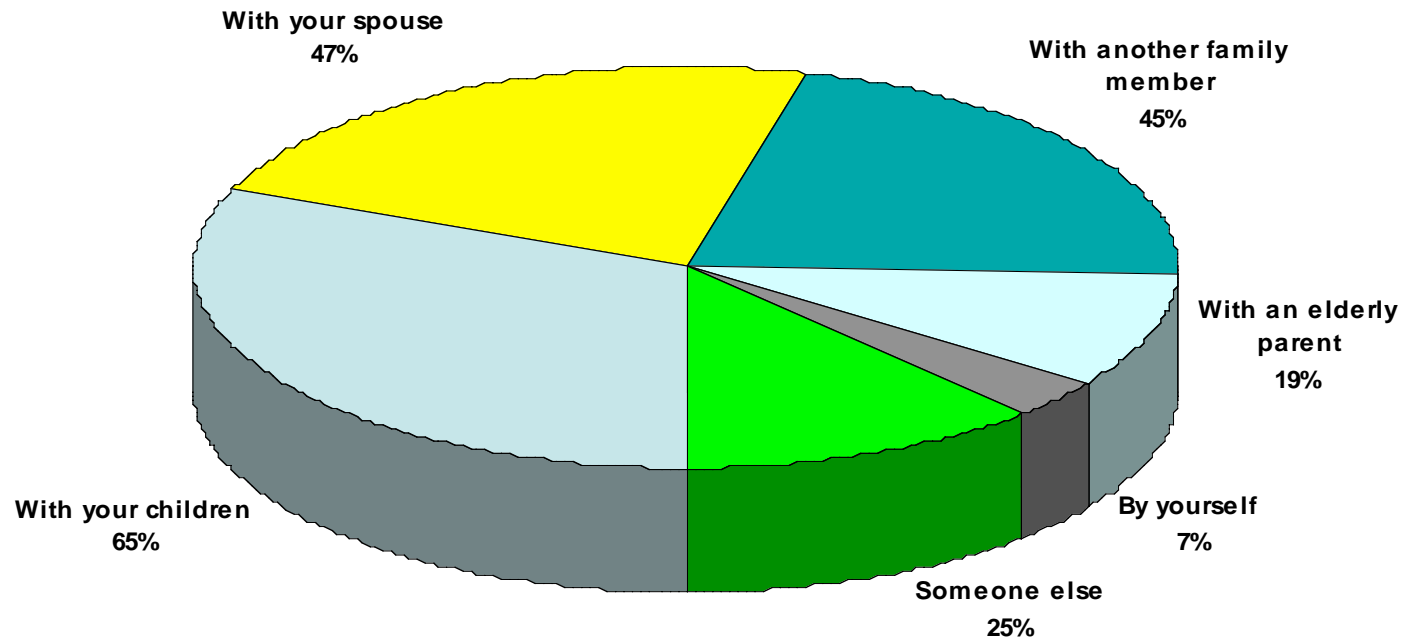

BASE: Telephone and in-person respondents (n=404)

What do you recall seeing or hearing prior to the hurricane making landfall?

- § *I recall the wind and the glass breaking. I recall the rain. It made me scared to death. I was terrified.*
- § *We were out of town and were evacuated that Wednesday. We had less than 72 hours to get out of town. It made me very scared and disoriented. The routes they had people driving on to get out of town was ridiculous. People were running out of gas. It was frightening and unorganized.*
- § *I have been involved in hurricanes before. With this hurricane, it was Sunday morning. We knew it was straight up coming. We packed up and moved to my aunts and the hurricane hit that night. It was heart-breaking. We did not know what we were going to go back to. At least five of my family members lost everything.*
- § *I could hear a lot of wind, the roaring of the wind. Tornado like winds, the roaring of the wind was tornado like. I have experienced a tornado before and it is a very eerie sound. Windows were blown out and roofs were damaged. I had doors blown open that were shut, and there was flooding from all the rain. The waves that came in covered about 5 miles from landfall, from the beach area itself. We were able to escape because we went to a shelter. I was injured, and so it took me longer to get out, and we were almost too late in getting out. It was quite scary and I have never experienced anything thing like that. Nothing as devastating as that. I have been in tornadoes, but I have never experienced hurricane disaster. When you find out that there were deaths because of the flooding and such, even though you did not know the people, you could imagine because you saw the flooding. It is just devastating to know that people died because of this. Some people lost everything, and they are having to start over. Some homes were completely demolished. There was a lot of wind damage, homes were gutted from the wind and the things were strung all up in the trees.*
- § *I saw trees falling down and people scared and panicking. We had to leave our house and were running over trees and falling power lines. We were praying and walking to my uncle's house and we were scared.*

Recollections Before Katrina Made Landfall

Q1600: What do you recall seeing or hearing prior to the hurricane making landfall?

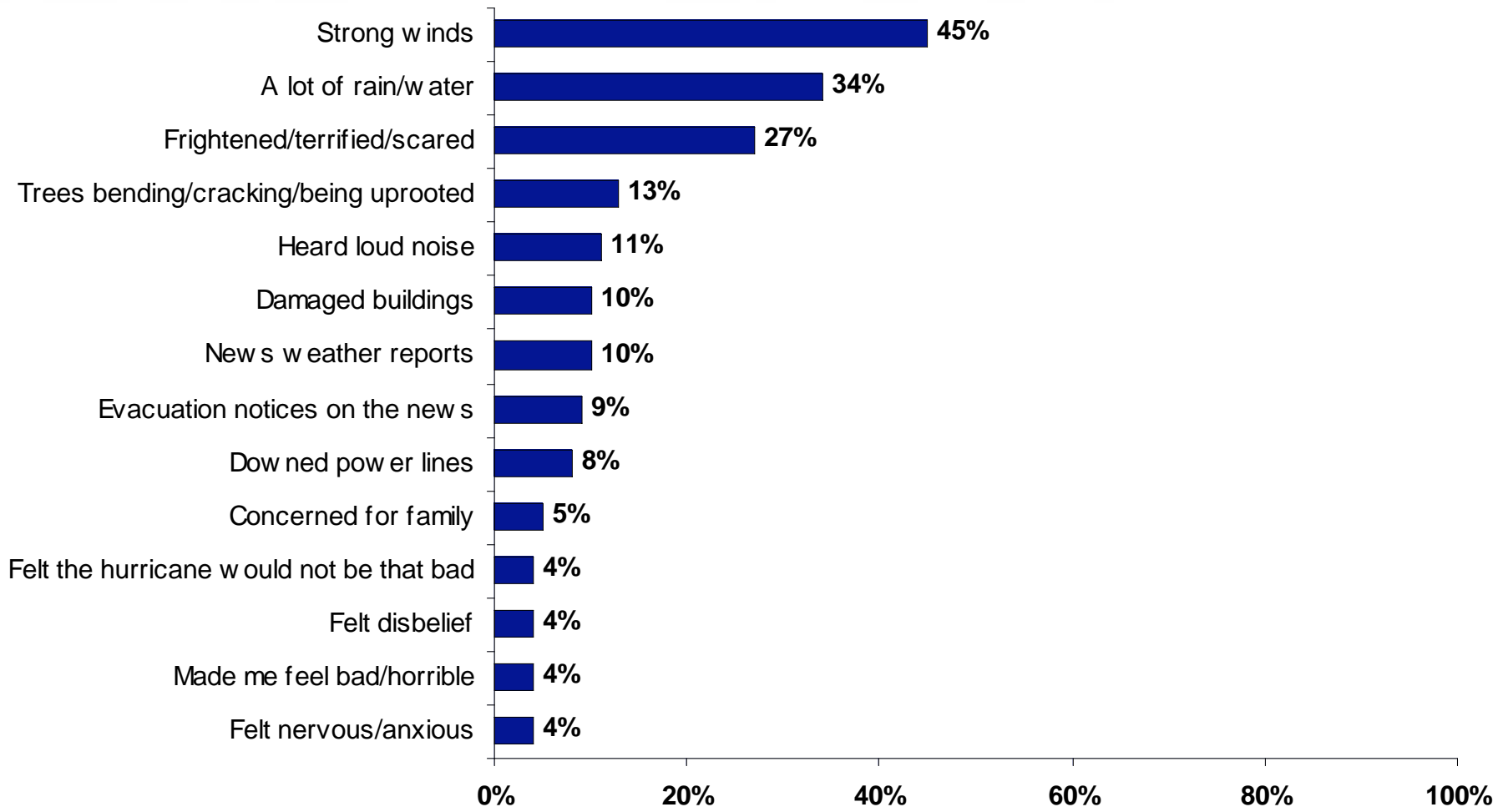

BASE: Telephone and in-person respondents (n=404)

What do you recall seeing or hearing after the hurricane made landfall?

- § *We did not have any heat. We had to barricade ourselves and had to stay inside. The streets were blocked off. It was like we had to live in the older days. We had to buy food day to day. We could not shower. It was very miserable and it was hard on the kids. I could not believe it, it was shocking.*
- § *Water and destruction. Cries for help. We were in the attic and on our roof for three days.*
- § *Feeling of relief for my family still being there.*
- § *Water coming up and rain still coming down. It was a nightmare, people calling for help.*
- § *We were out of the city. Then we went to my parents because my mother needed dialysis. It was hard to find a place to take her for her dialysis. St. Patrick's hospital should have given a list to call so people can receive proper medical care. The third day she finally got into a medical care center and found family there. It was costly. It made me feel frustrated and angry.*
- § *I remember a lot of disbelief. There were lots of lives lost. There was depression and death. I remember the smell of the waste. It made me feel terrible.*

Recollections After Katrina Made Landfall

Q1605: What do you recall seeing or hearing after the hurricane made landfall?

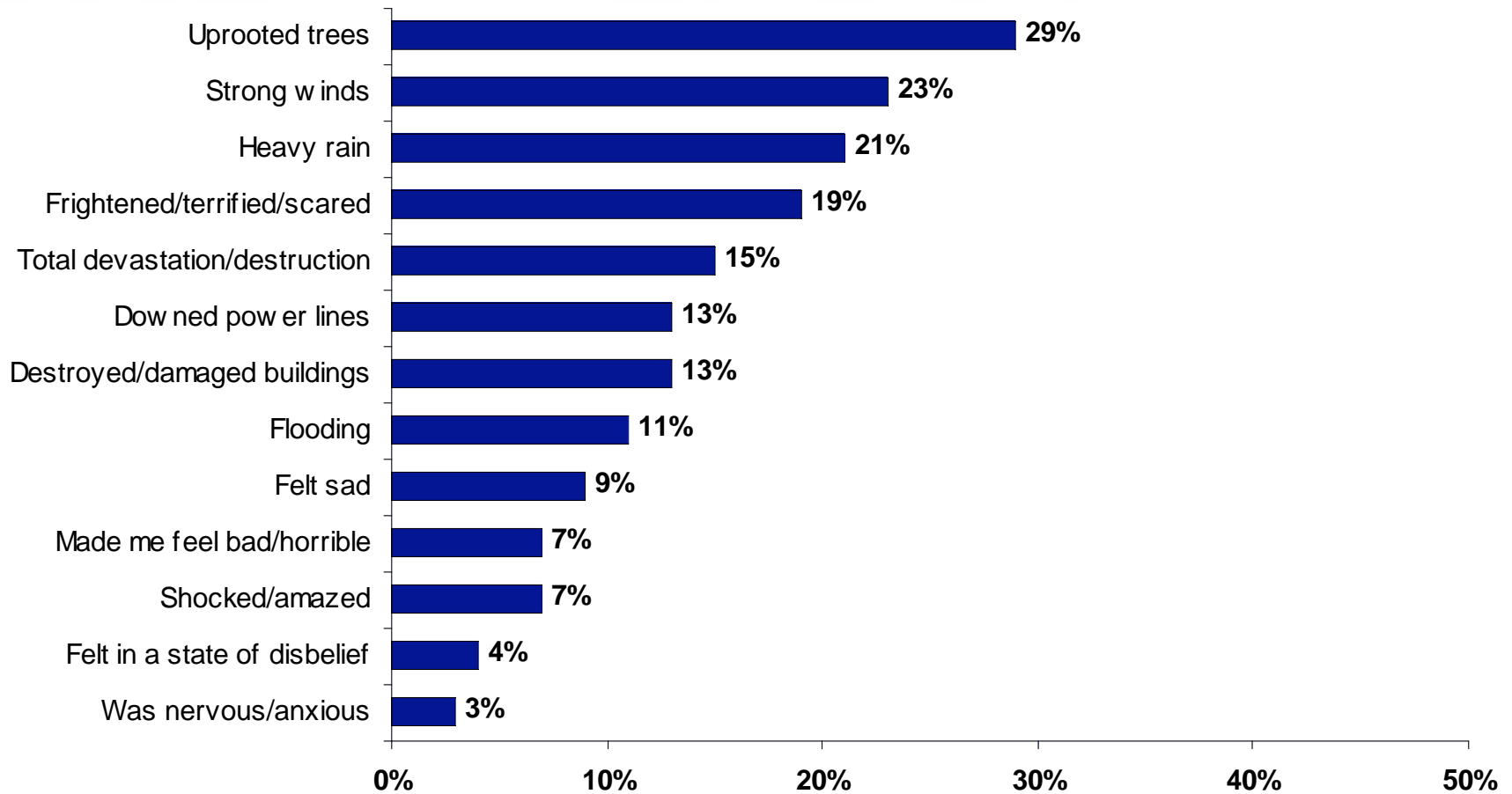

BASE: 404 Respondents

NOTE: Asked only of those interviews conducted via telephone or in-person

Rescue Operations

Patterns of Immediate Assistance

Q700: Once Hurricane Katrina struck in your area, when did the first help from outside reach your home?

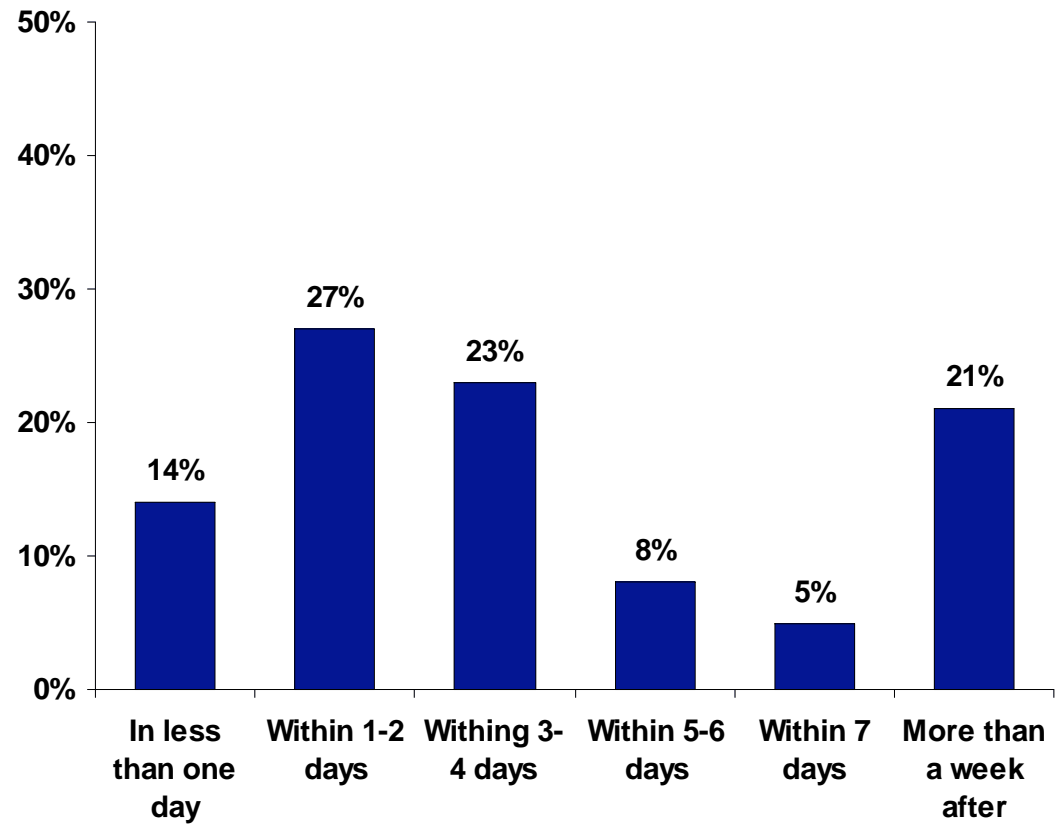
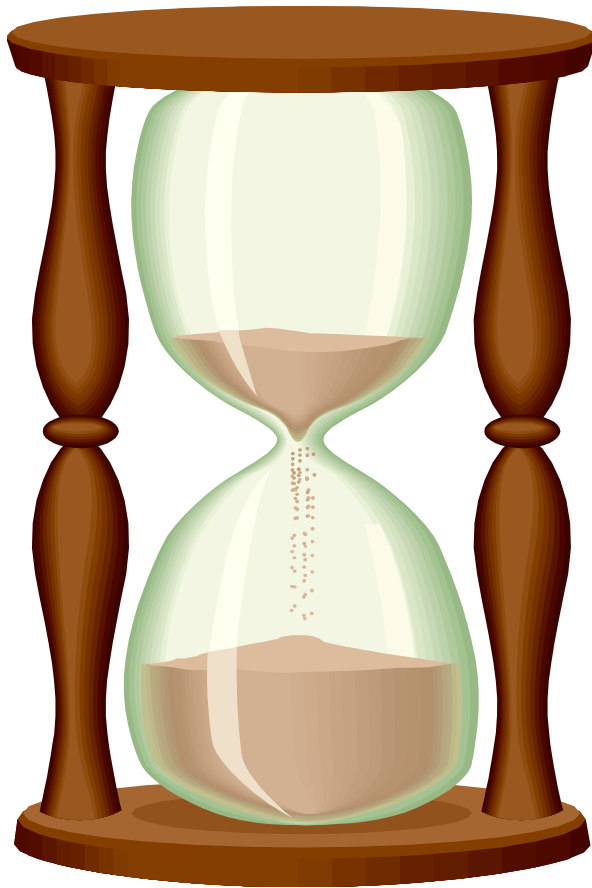

BASE: People who did not evacuate (n=430)

Patterns of Immediate Assistance

Q700: Once Hurricane Katrina struck in your area, when did the first help from outside reach your home?

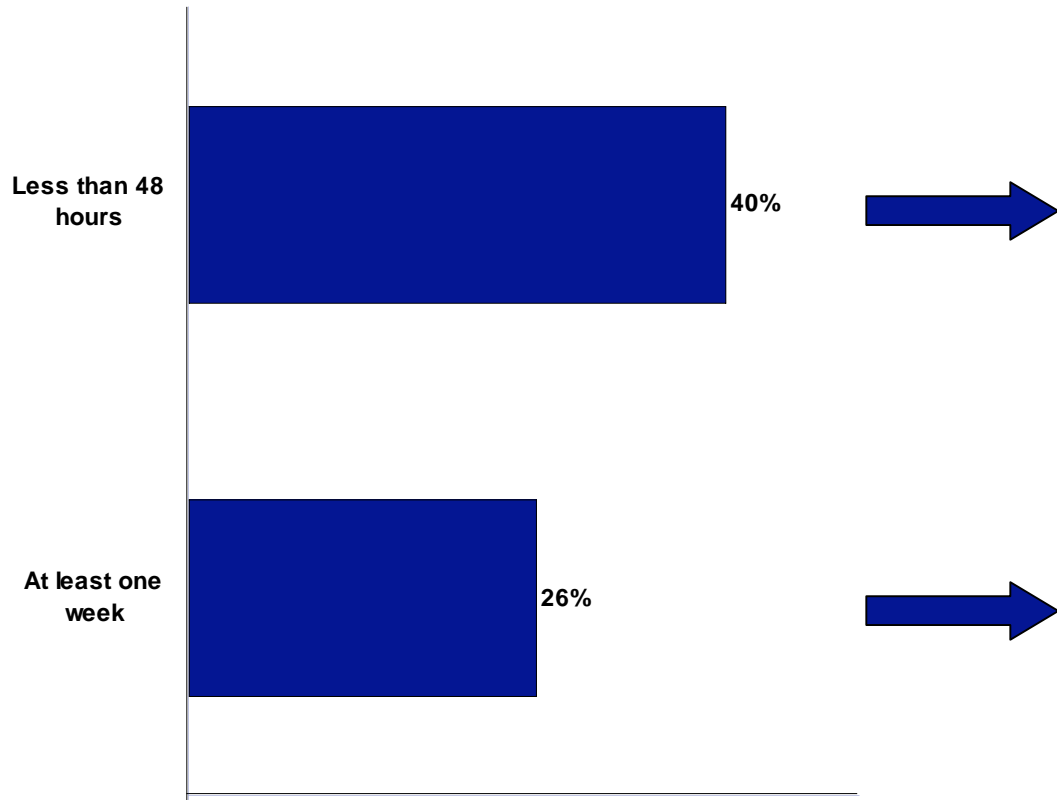

Income more than \$50,000	52%
Alabama	50%
White	47%
Do not have disabilities	44%
Do not have children	44%
Men	44%
Live in single family homes	43%
Have a college education or more	43%
Mississippi	42%
Non-evacuees by choice	40%
Louisiana	32%

Have a disability	43%
Louisiana	40%
Other ethnic minorities	35%
Income less than \$35,000	33%
African American	33%
Non-evacuees because of means	30%
35-54	30%

BASE: People who did not evacuate (n=430)

Organizations Providing Immediate Assistance

Q705: In the first 48 hours, who came to help?

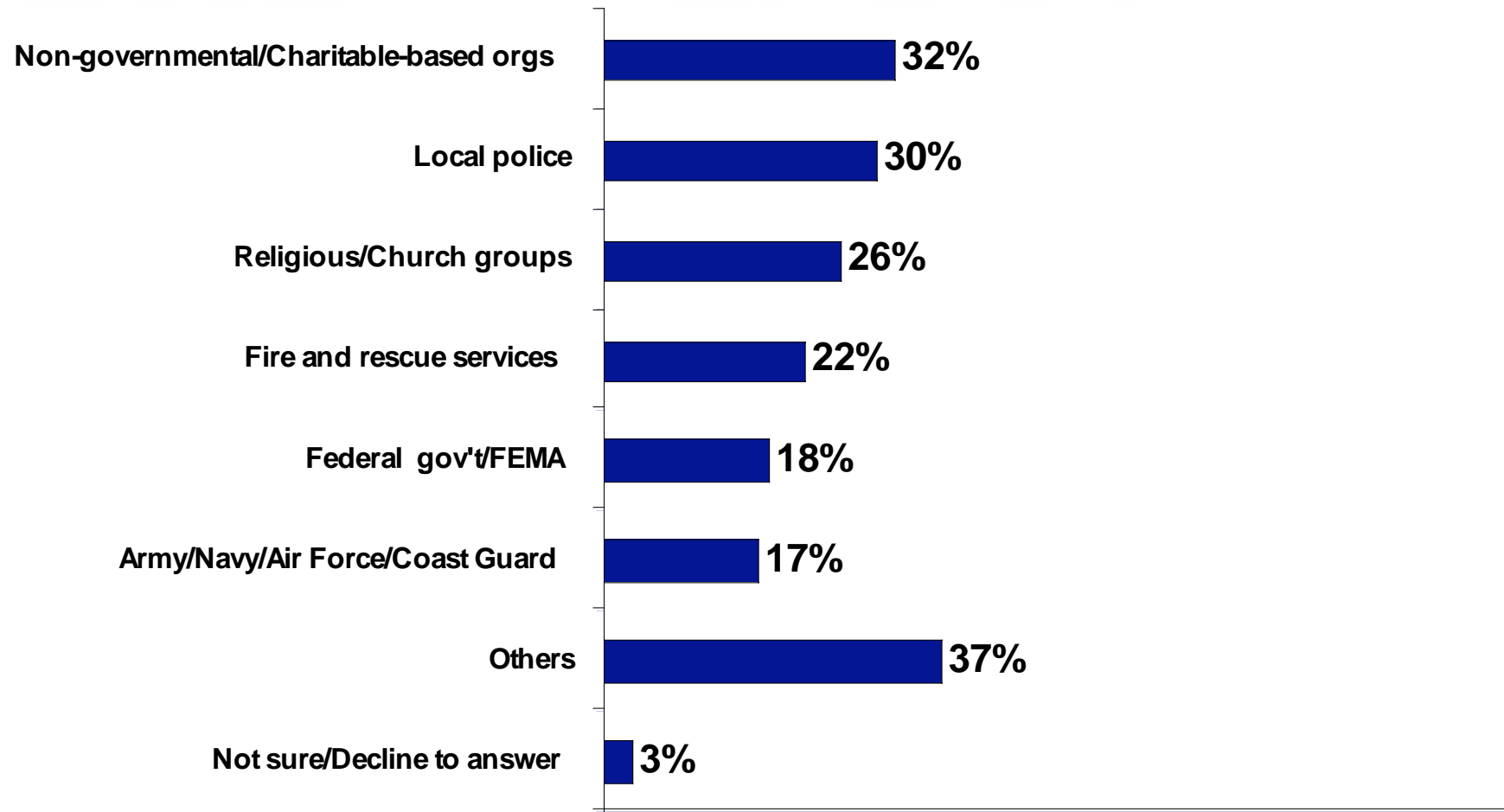

BASE: People who did not evacuate and received help in the first 48 hours (n=154)

Relief Operations

Post-Katrina Relief Services

A Closer Look at the First Month After Katrina

Q795: Within the first month, which of the following relief services have you received?

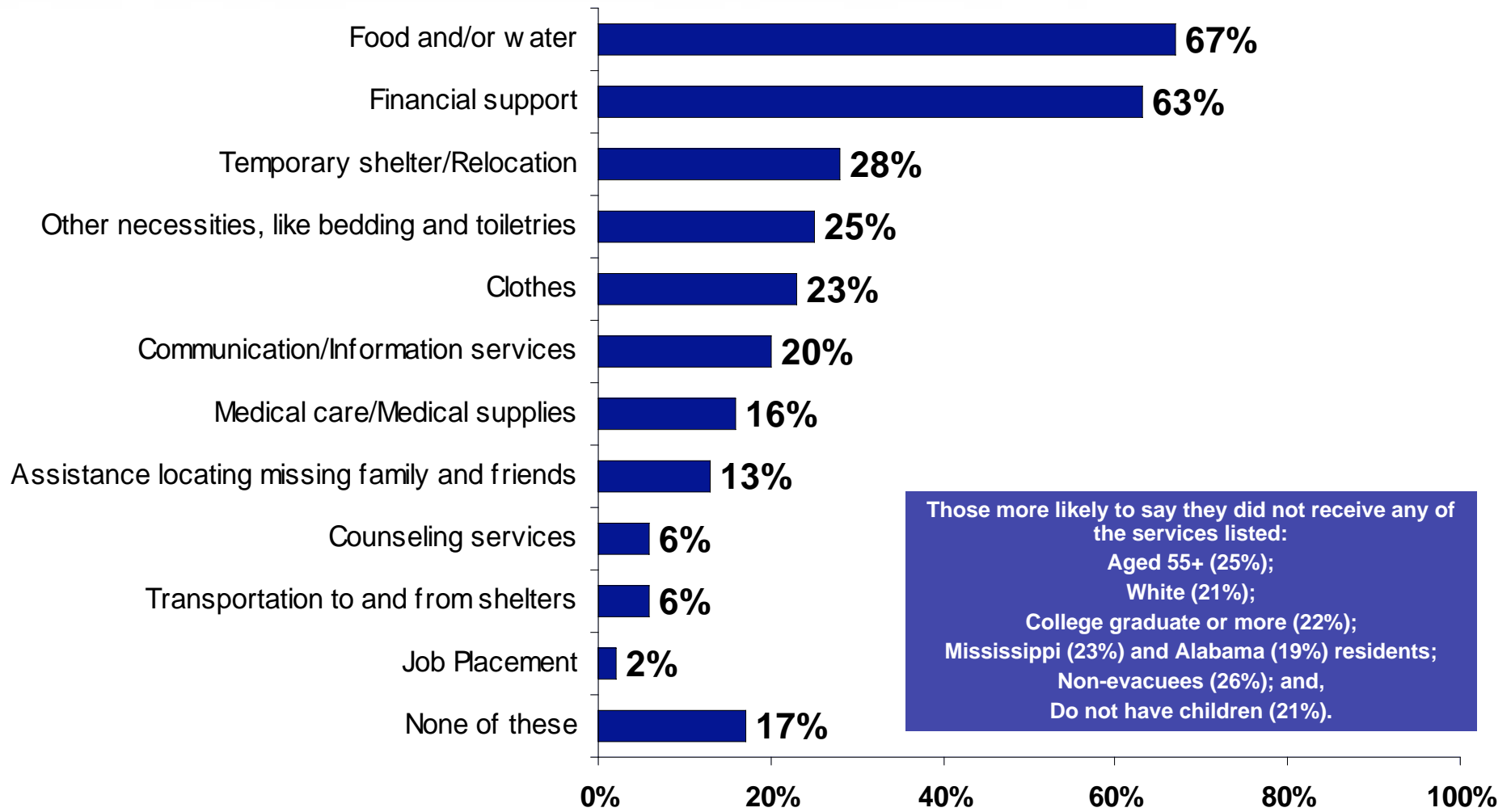

BASE: All respondents (n=1,089)

Post-Katrina Relief Services

Food/Water

Q795 – Within the first month, which of the following relief services did you receive?

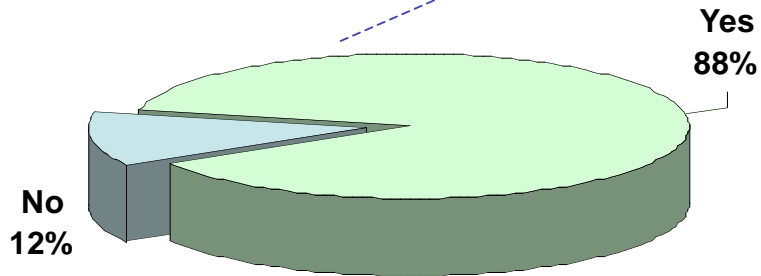

Q800 – We would like to ask you in more detail about the food / water relief you received. Was it...?

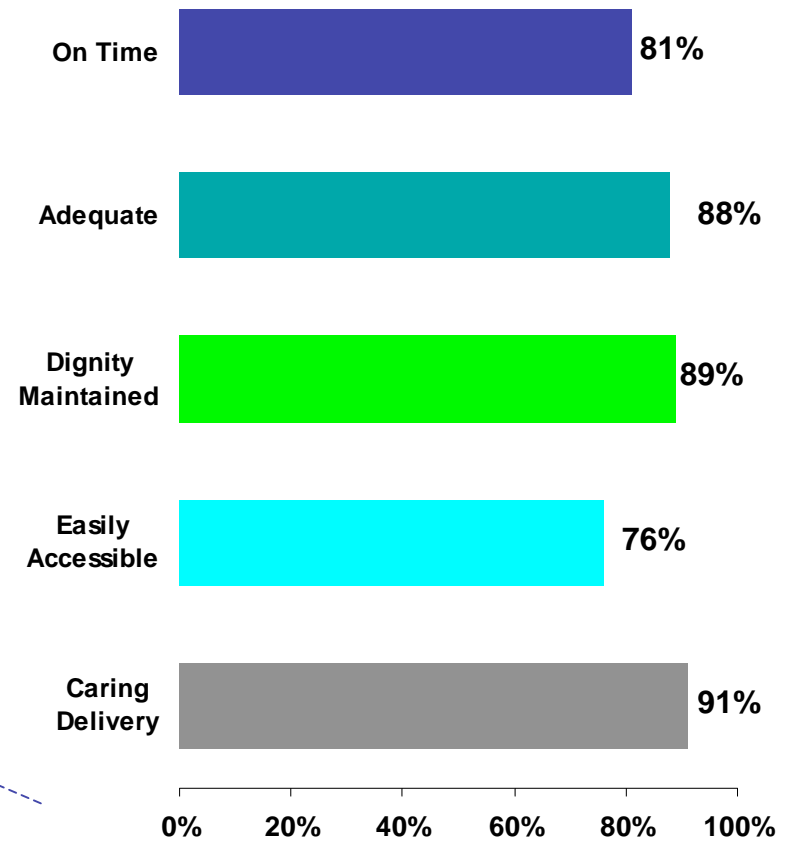

BASE: 732

Post-Katrina Relief Services

Temporary Shelter/Relocation

Q795 – Within the first month, which of the following relief services did you receive?

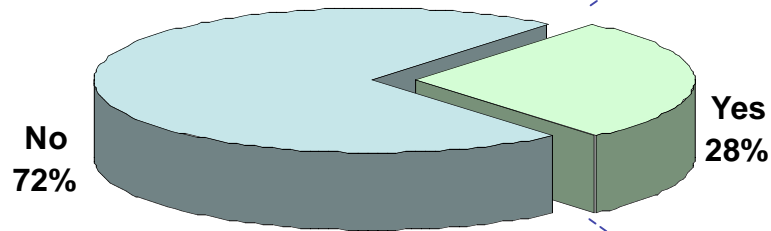

Q800 – We would like to ask you in more detail about the temporary shelter / relocation relief you received. Was it...?

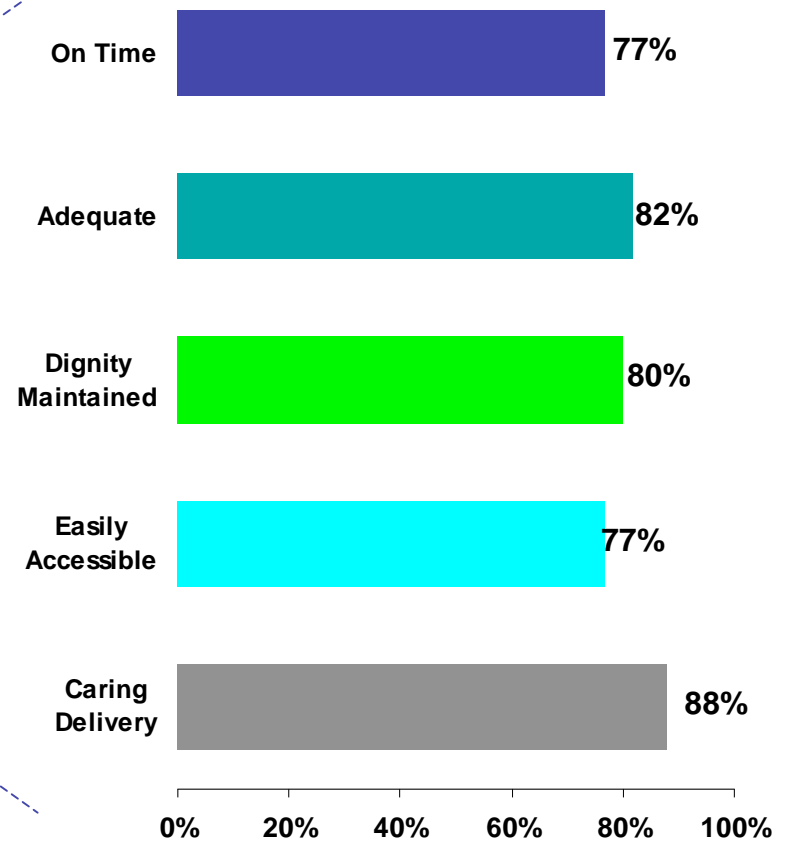

Post-Katrina Relief Services

Clothes

Q795 – Within the first month, which of the following relief services did you receive?

Q800 – We would like to ask you in more detail about the clothes relief you received. Was it...?

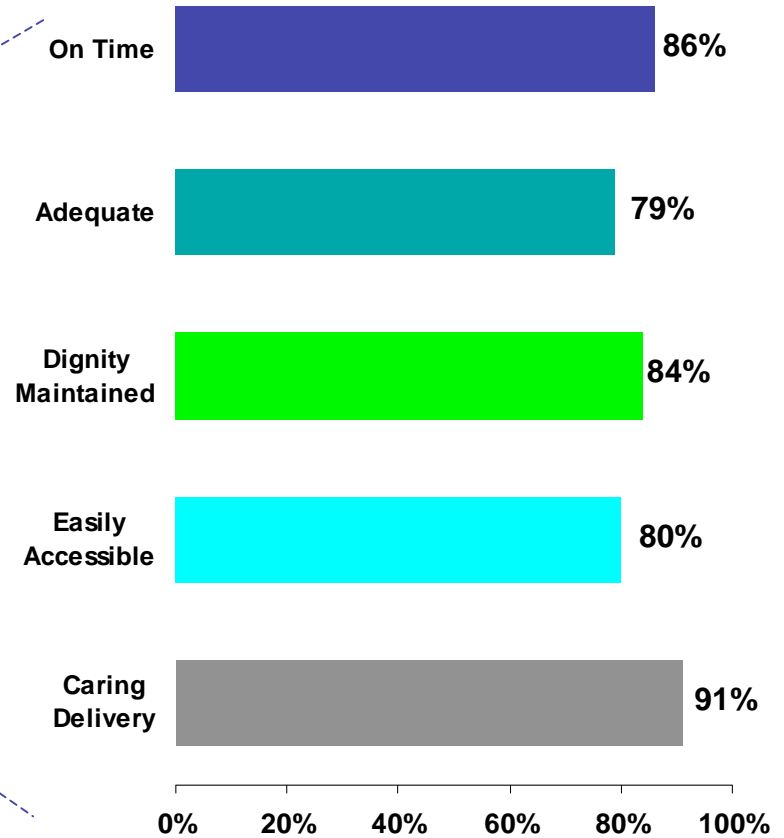
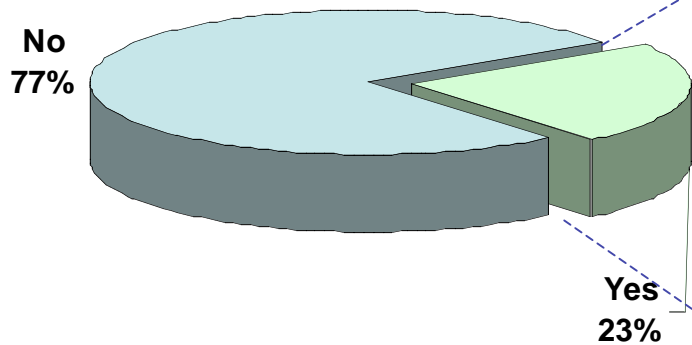

BASE: 246

Post-Katrina Relief Services

Counseling Services

Q795 – Within the first month, which of the following relief services did you receive?

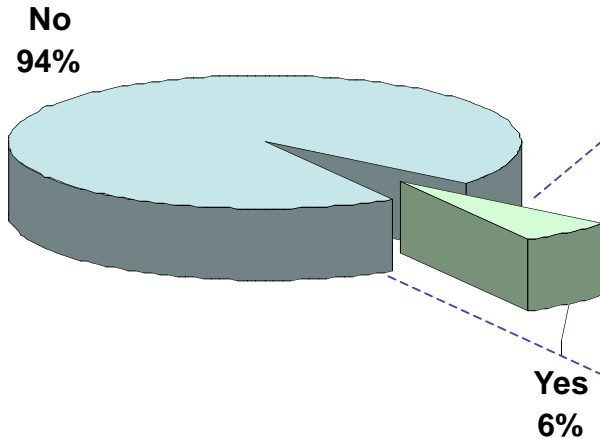

Q800 – We would like to ask you in more detail about the counseling services relief you received. Was it...?

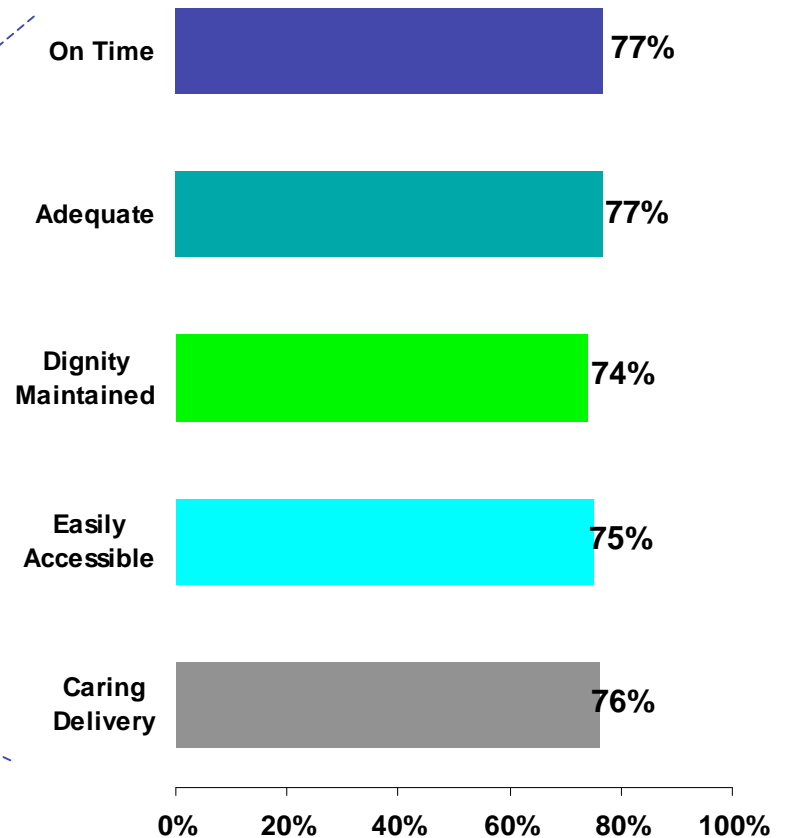

BASE: 61*

Post-Katrina Relief Services

Communication/Information Services

Q795 – Within the first month, which of the following relief services did you receive?

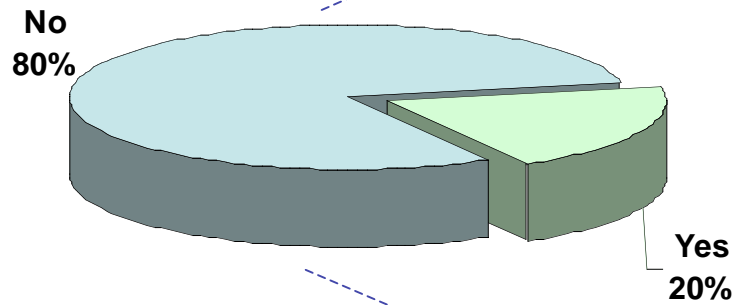

Q800 – We would like to ask you in more detail about the communication / information services relief you received. Was it...?

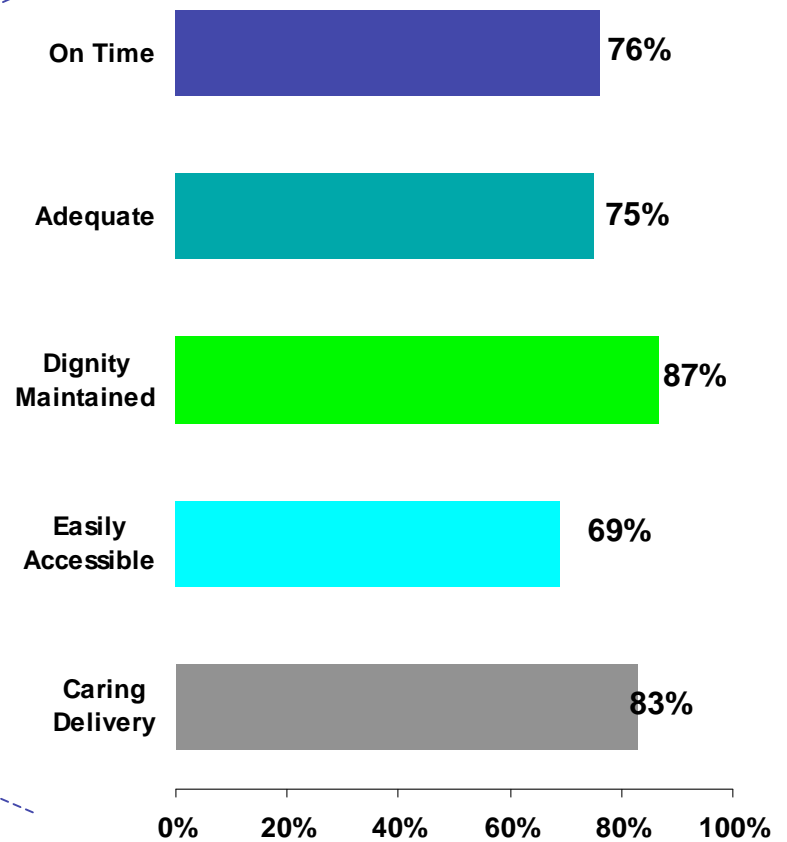

BASE: 200

Post-Katrina Relief Services

Financial Support

Q795 – Within the first month, which of the following relief services did you receive?

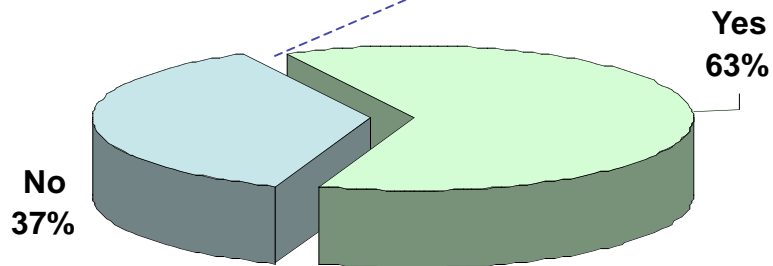

Q800 – We would like to ask you in more detail about the financial support relief you received. Was it...?

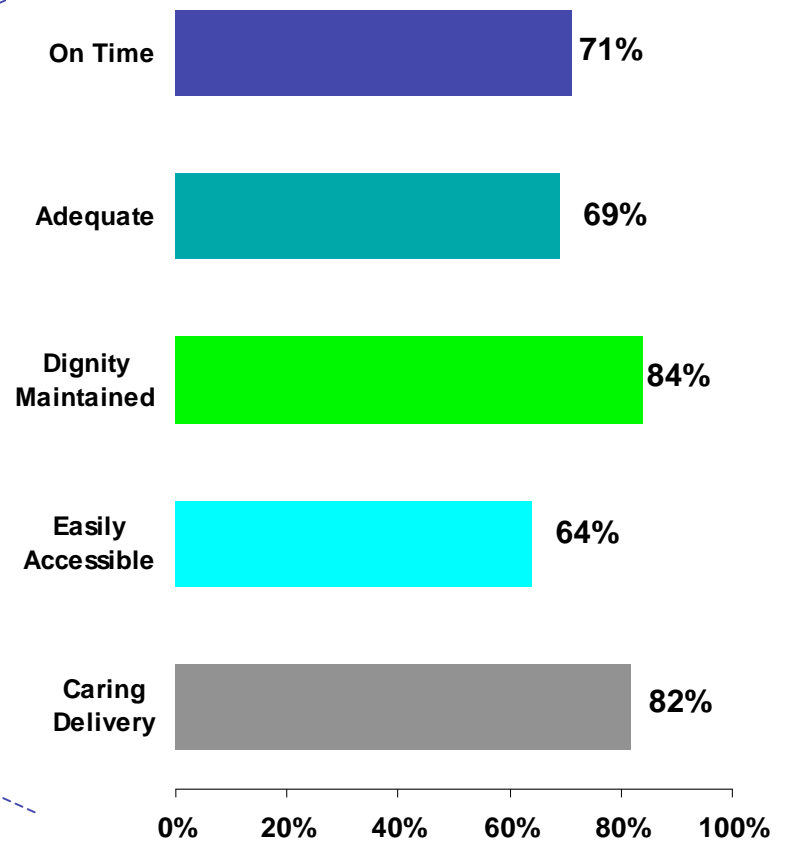

BASE: 697

Post-Katrina Relief Services

Assistance Locating Missing Family and Friends

Q795 – Within the first month, which of the following relief services did you receive?

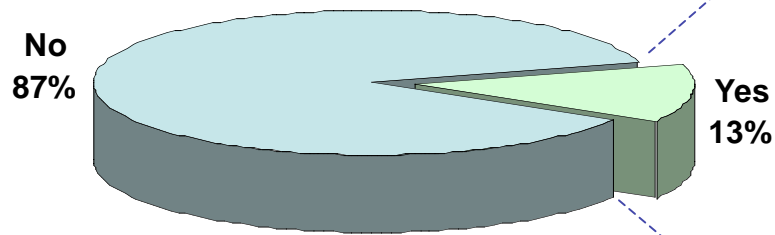

Q800 – We would like to ask you in more detail about the assistance locating missing family and friends relief you received. Was it...?

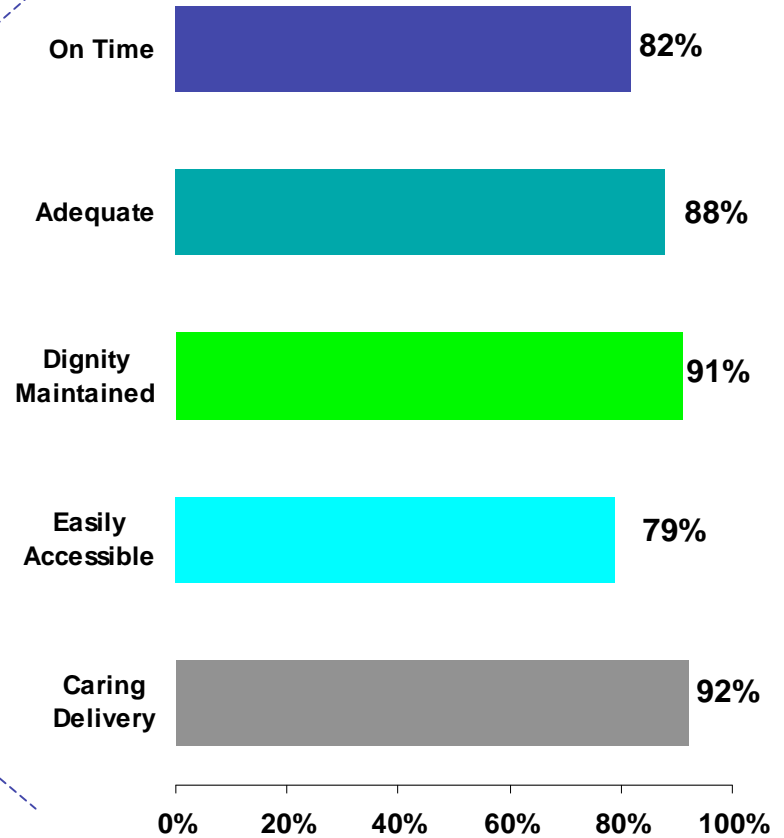

Post-Katrina Relief Services

Transportation to and from Shelters

Q795 – Within the first month, which of the following relief services did you receive?

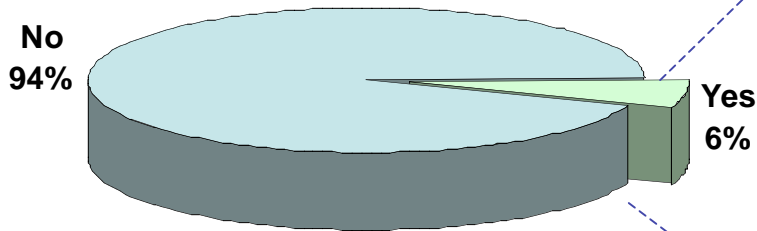

Q800 – We would like to ask you in more detail about the transportation to and from shelters relief you received. Was it...?

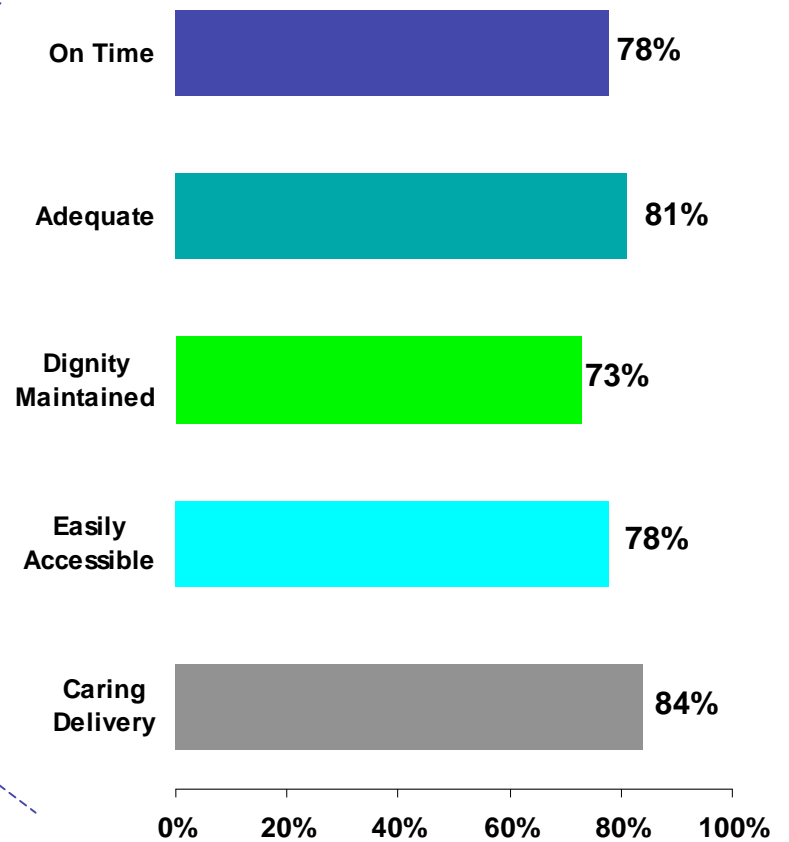

BASE: 59*

Post-Katrina Relief Services

Job Placement

Q795 – Within the first month, which of the following relief services did you receive?

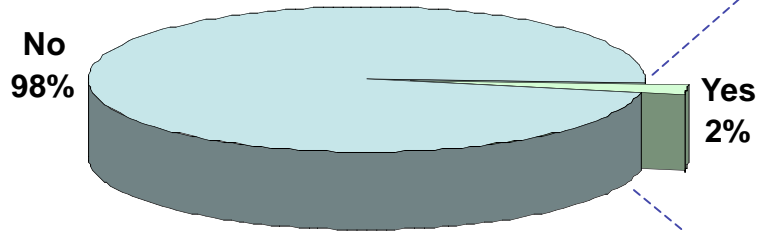

Q800 – We would like to ask you in more detail about the job placement relief you received. Was it...?

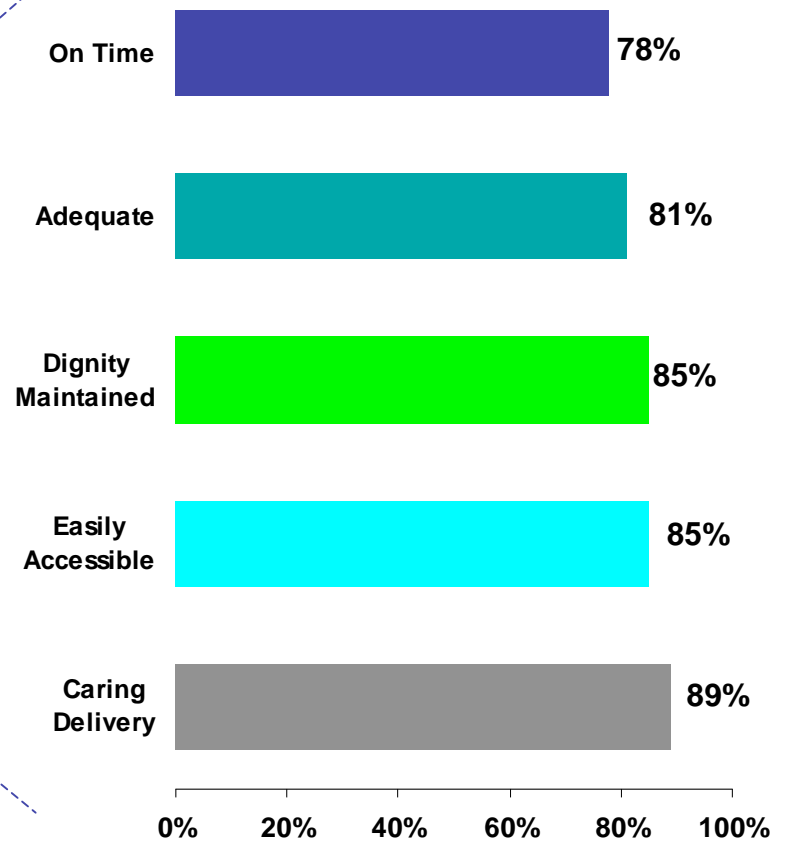

BASE: 27*

Post-Katrina Relief Services

Medical Care/Medical Supplies

Q795 – Within the first month, which of the following relief services did you receive?

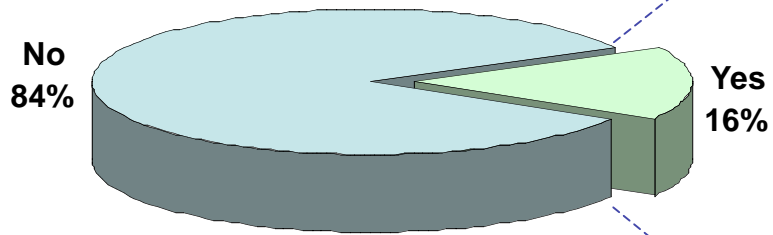

Q800 – We would like to ask you in more detail about the medical care / medical supplies relief you received. Was it...?

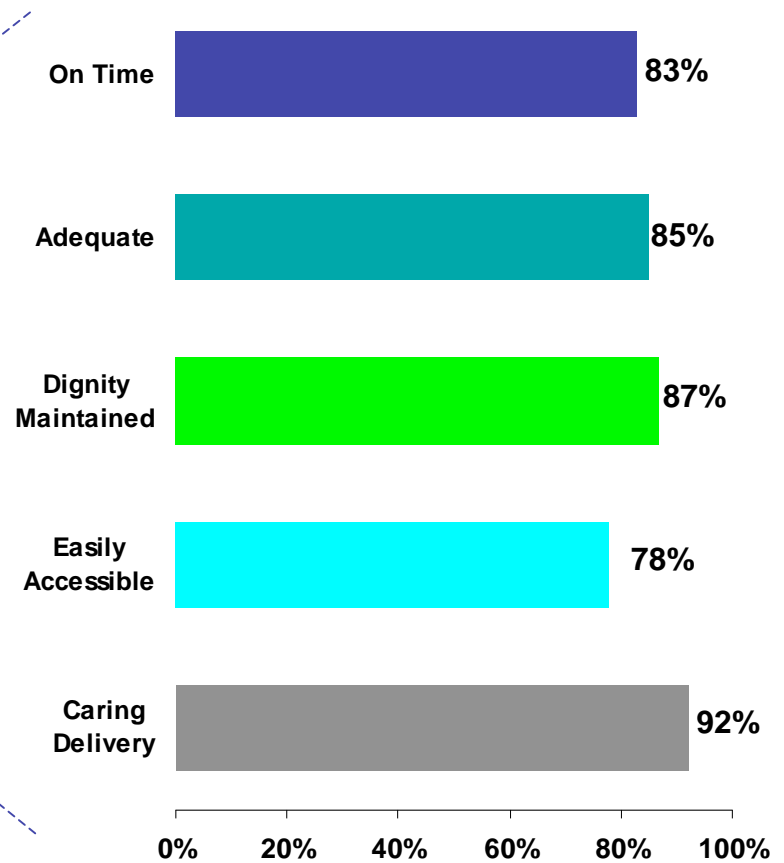

Post-Katrina Relief Services

Other Necessities, Like Bedding and Toiletries

Q795 – Within the first month, which of the following relief services did you receive?

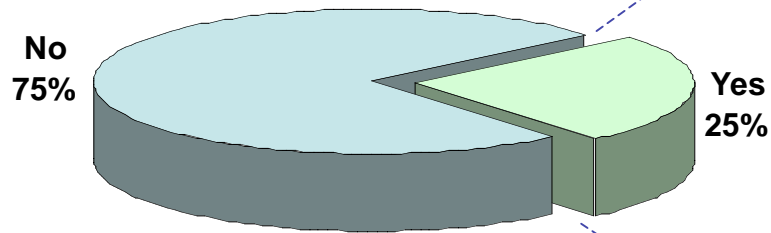

Q800 – We would like to ask you in more detail about the other necessities, like bedding and toiletries, relief you received. Was it...?

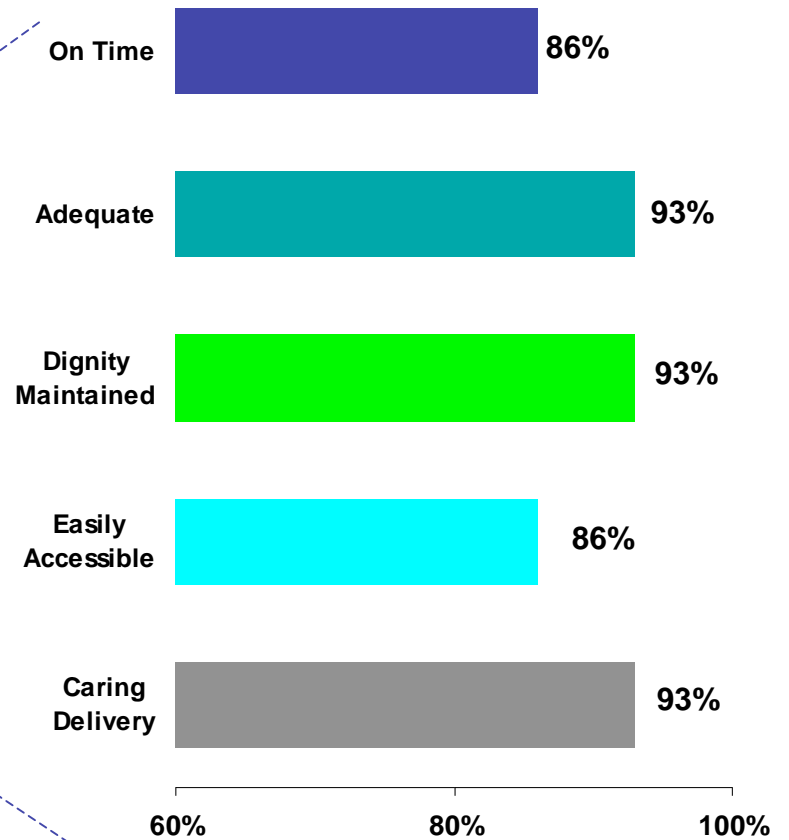

BASE: 247

Evaluation of Relief Services

Most Efficient Service

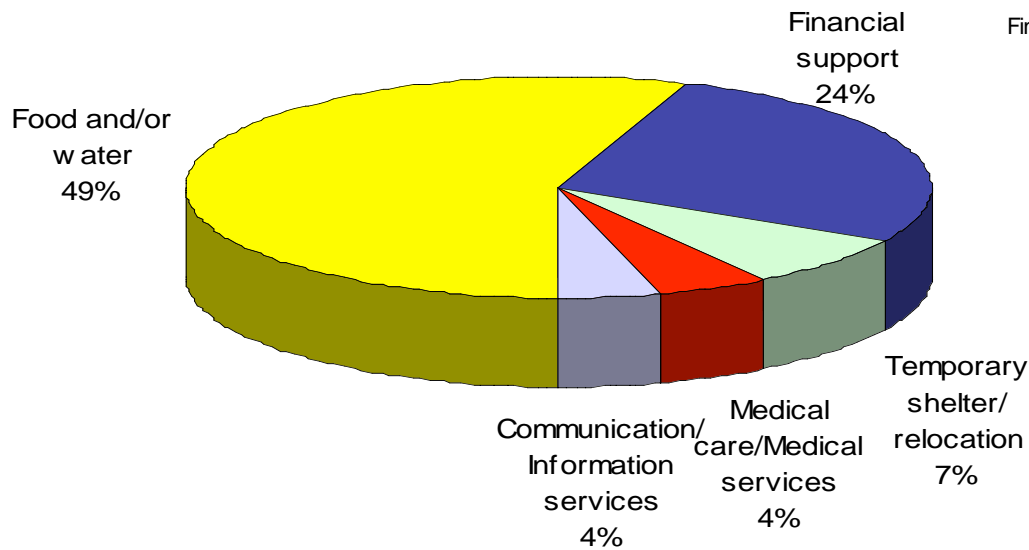

Q805: Of those you used, which service do you feel was delivered most efficiently?

Service Needing Most Improvement

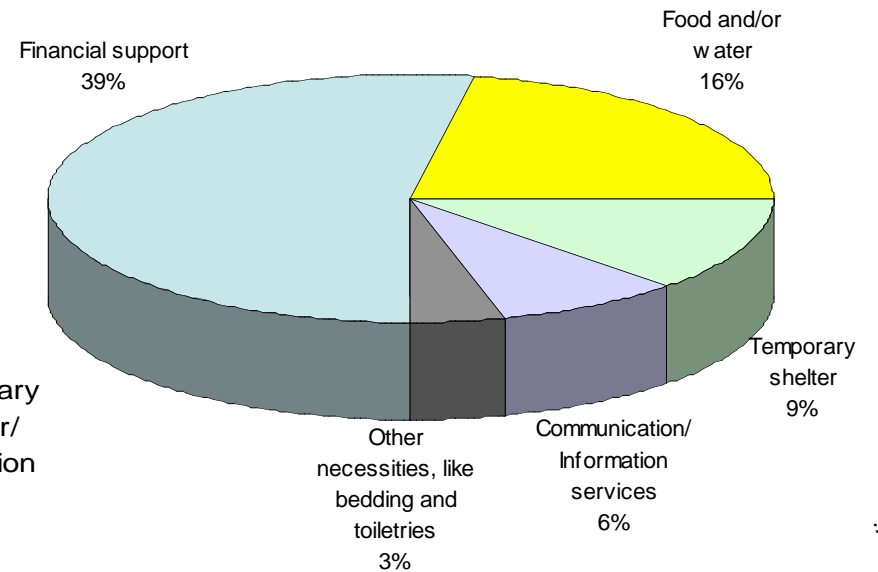

Q810: Which service do you feel could use the most improvement in terms of efficient service delivery?

BASE: All respondents (n=1,089)
 Note: Only top five mentions included.

Post-Katrina Relief Services

Highest Priority

Q815: What service that you have not received do you feel is currently your highest priority?

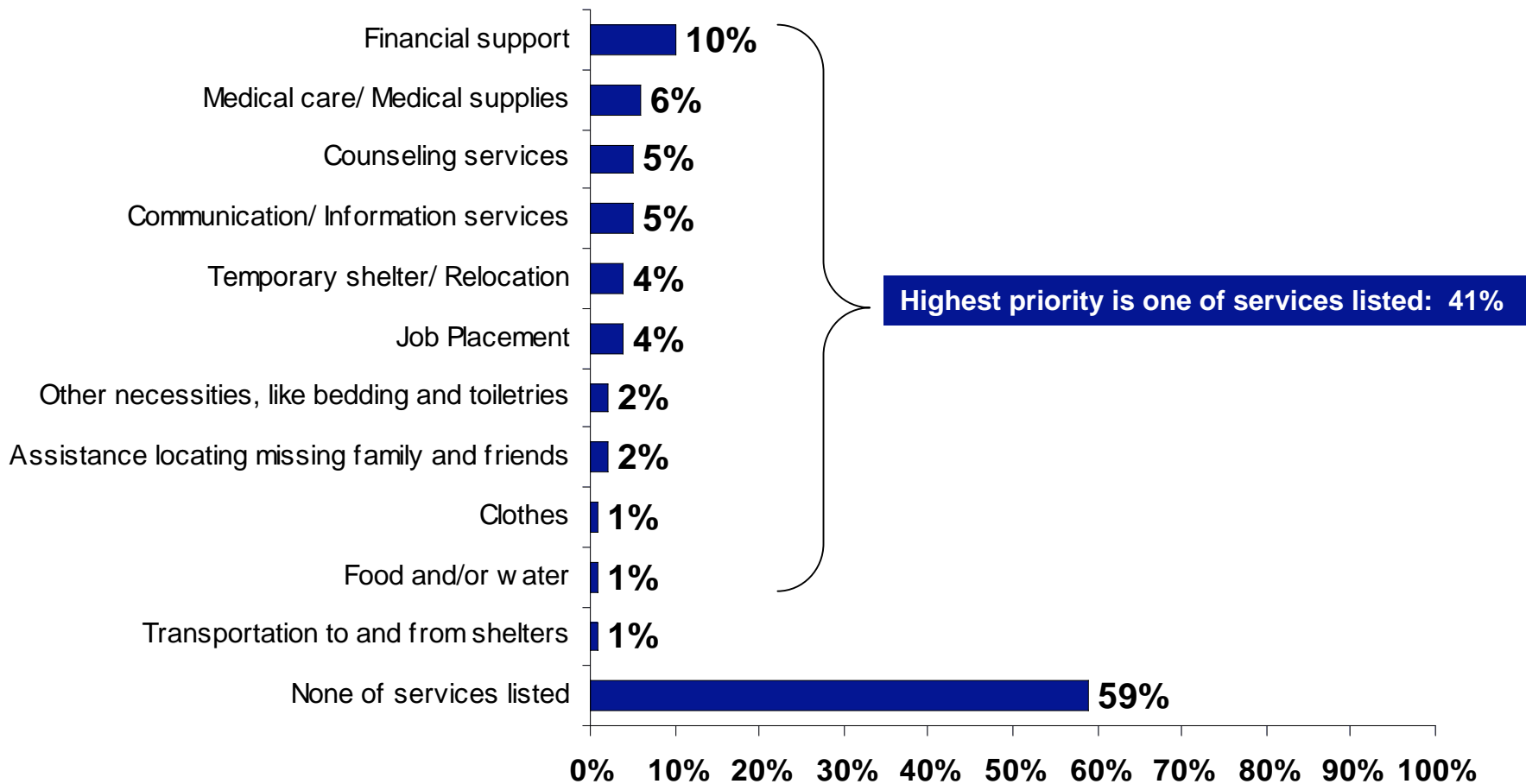

BASE: All respondents (n=1,089)

Additional Assistance

Q840: Have you gone back to any agency for additional services?

Q845: To which agency did you go?

Additional Relief Services

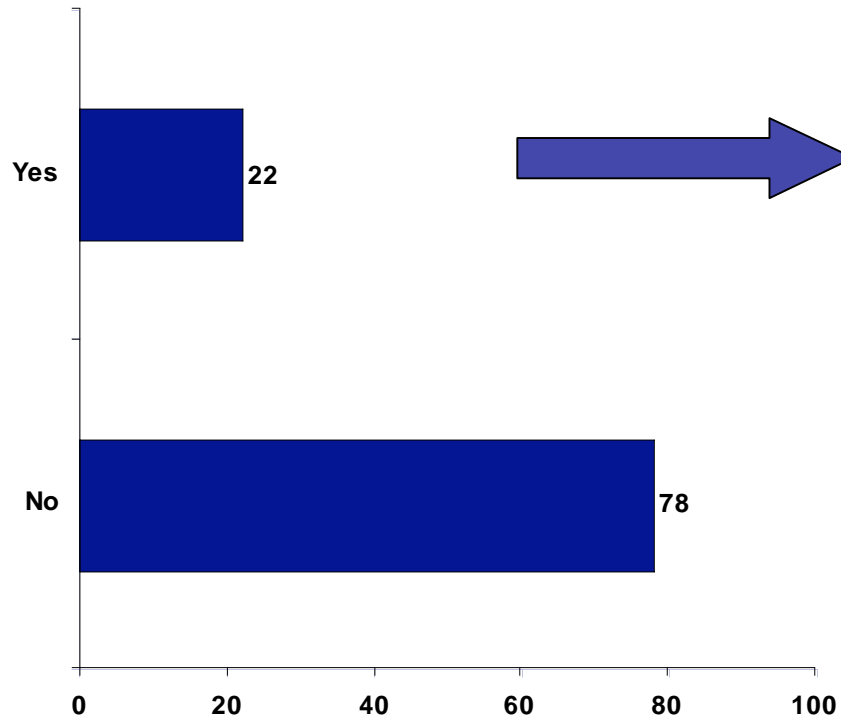

Type of Agency

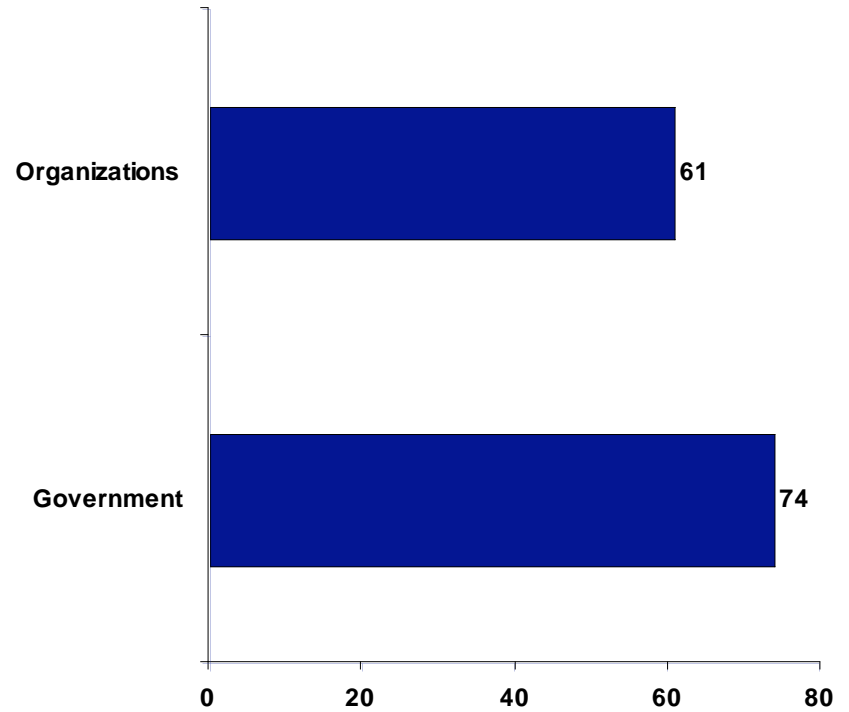

BASE: All respondents (n=1,089)

BASE: Those who went for additional relief services (n=236)

Additional Assistance

A Look at Specific Organizations

Q845: To which agencies did you go?

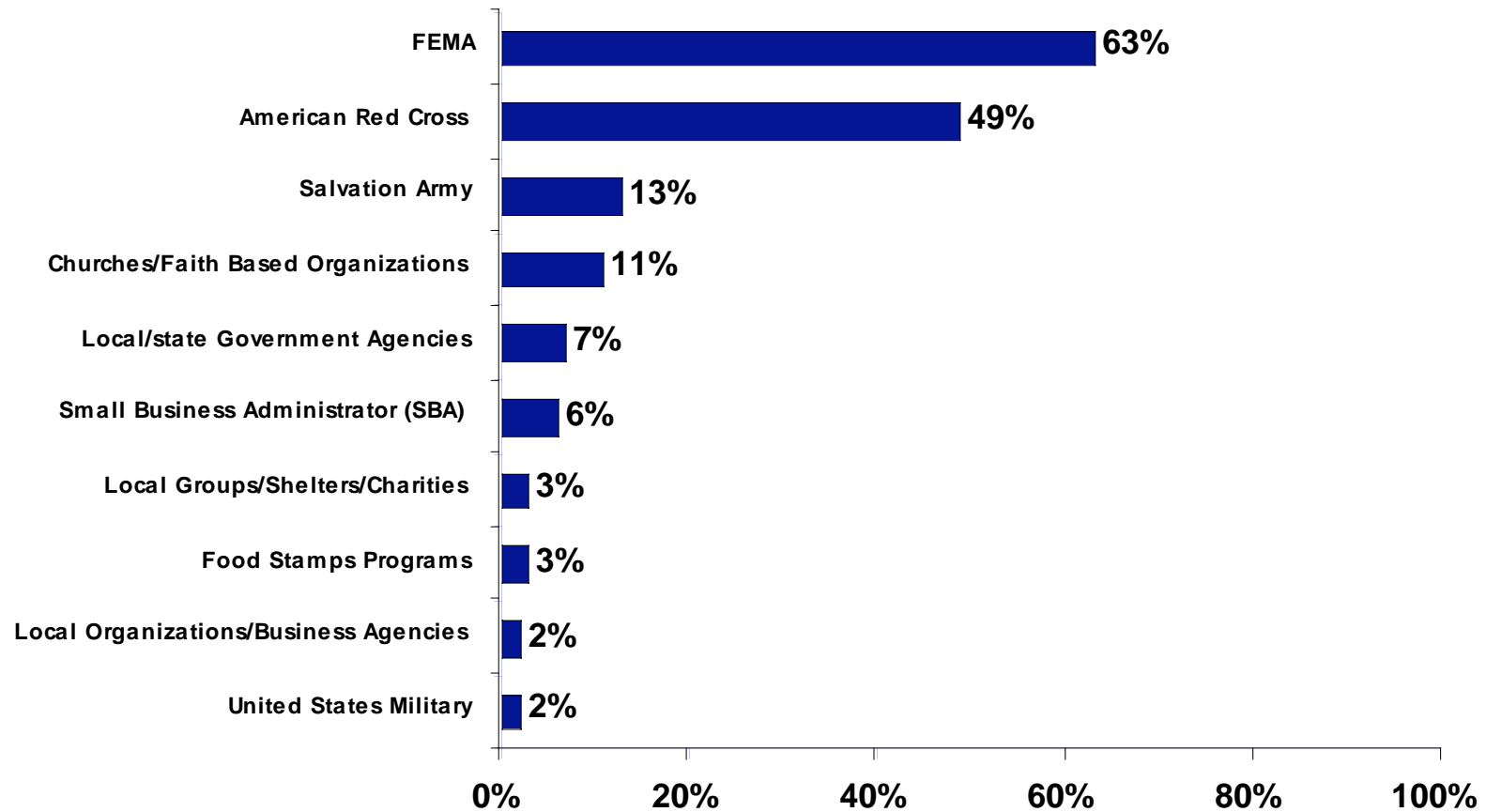

BASE: All respondents (n=1,089)

Note: Only mentions with more than 1% listed.

Post-Katrina Relief Services

Food and Water

Q1110: Why did you go to this agency?

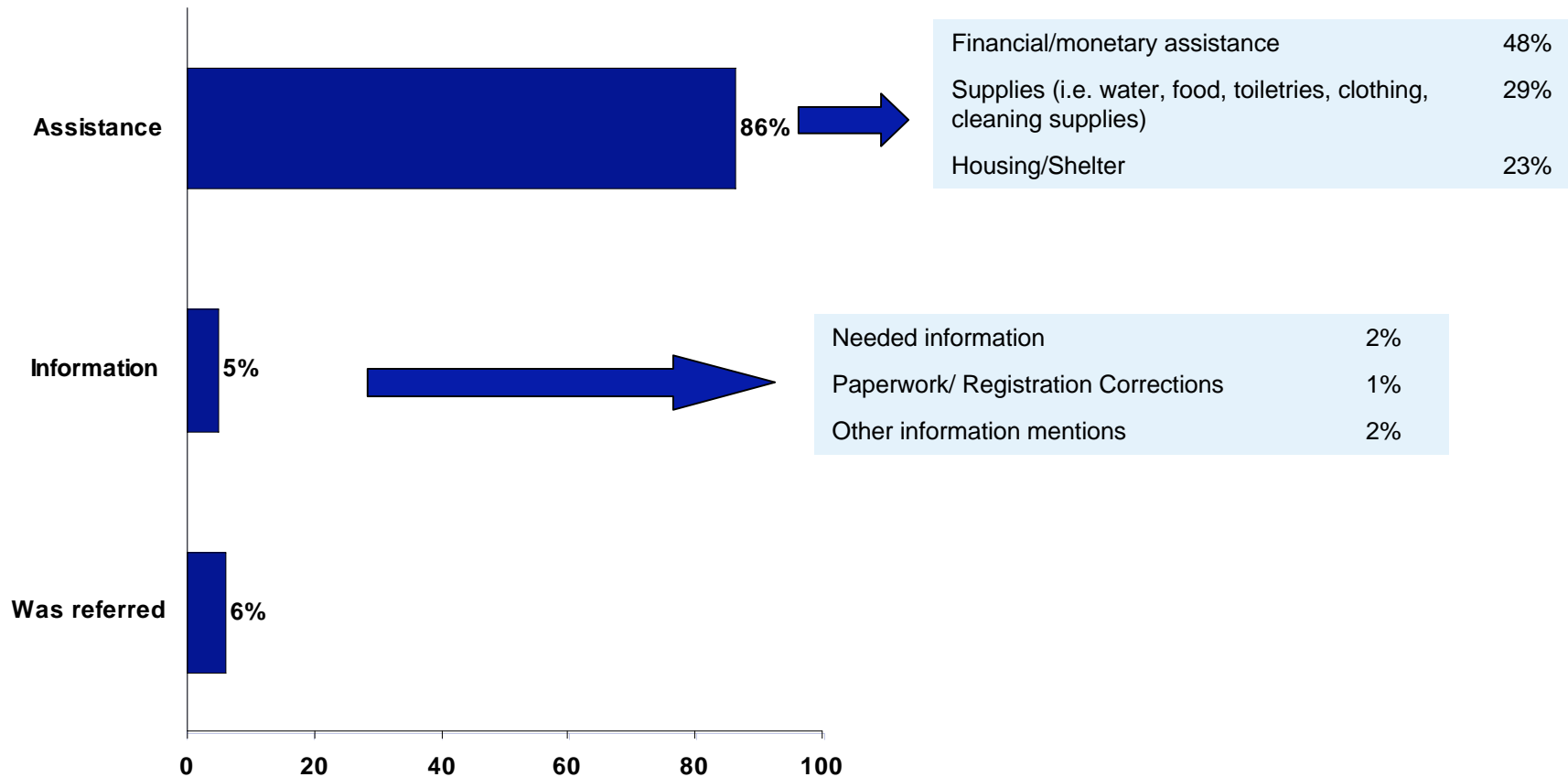

BASE: Victims seeking additional relief (n=235)

Evaluation of Relief Organizations

Evaluation of Relief Services

Most Efficient

Q820: Of all of the agencies giving relief, which one did you view to be the most efficient in delivering services?

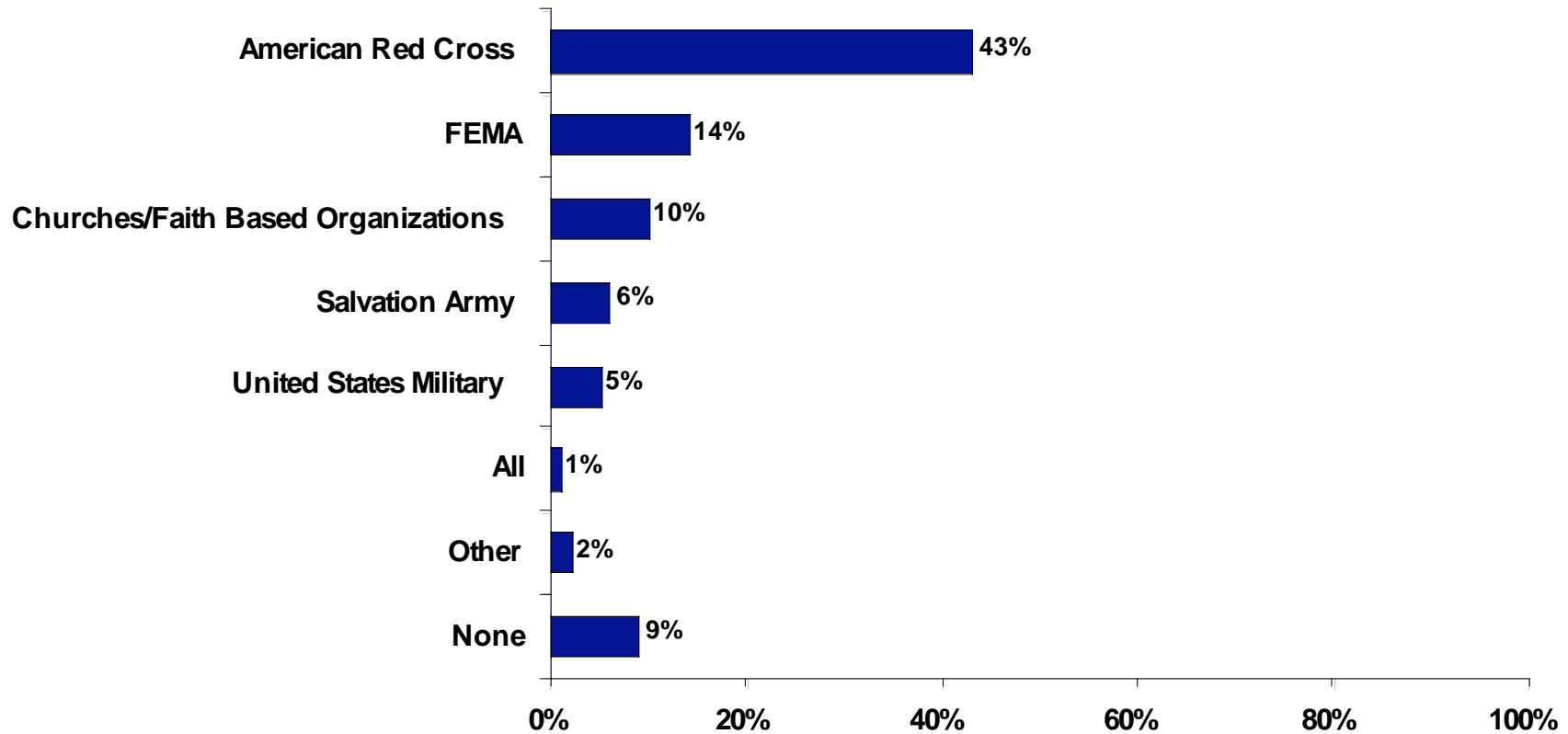

BASE: All respondents (n=1,089)

Note: Only ten five mentions included.

Evaluation of Relief Services

Most Effective

Q825: On a scale of 1 to 7, where 7 is "extremely effective" and 1 is "not at all effective," how would you rate the relief provided by each of the following organizations?

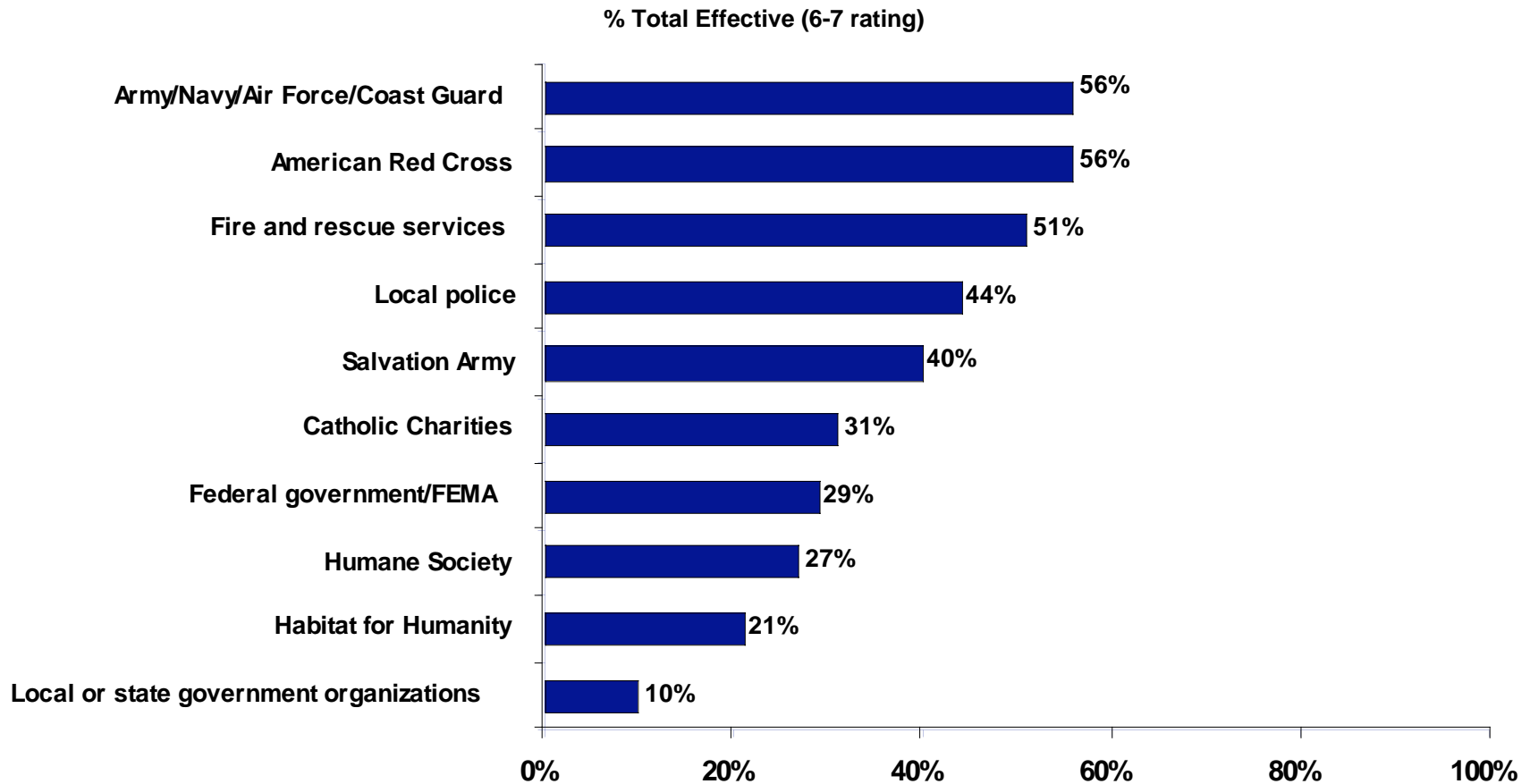

BASE: All respondents (n=1,089)

Evaluation of Relief Services

Best Overall Relief

Q830: If you could single out one agency that provided the best overall relief, which one would it be?

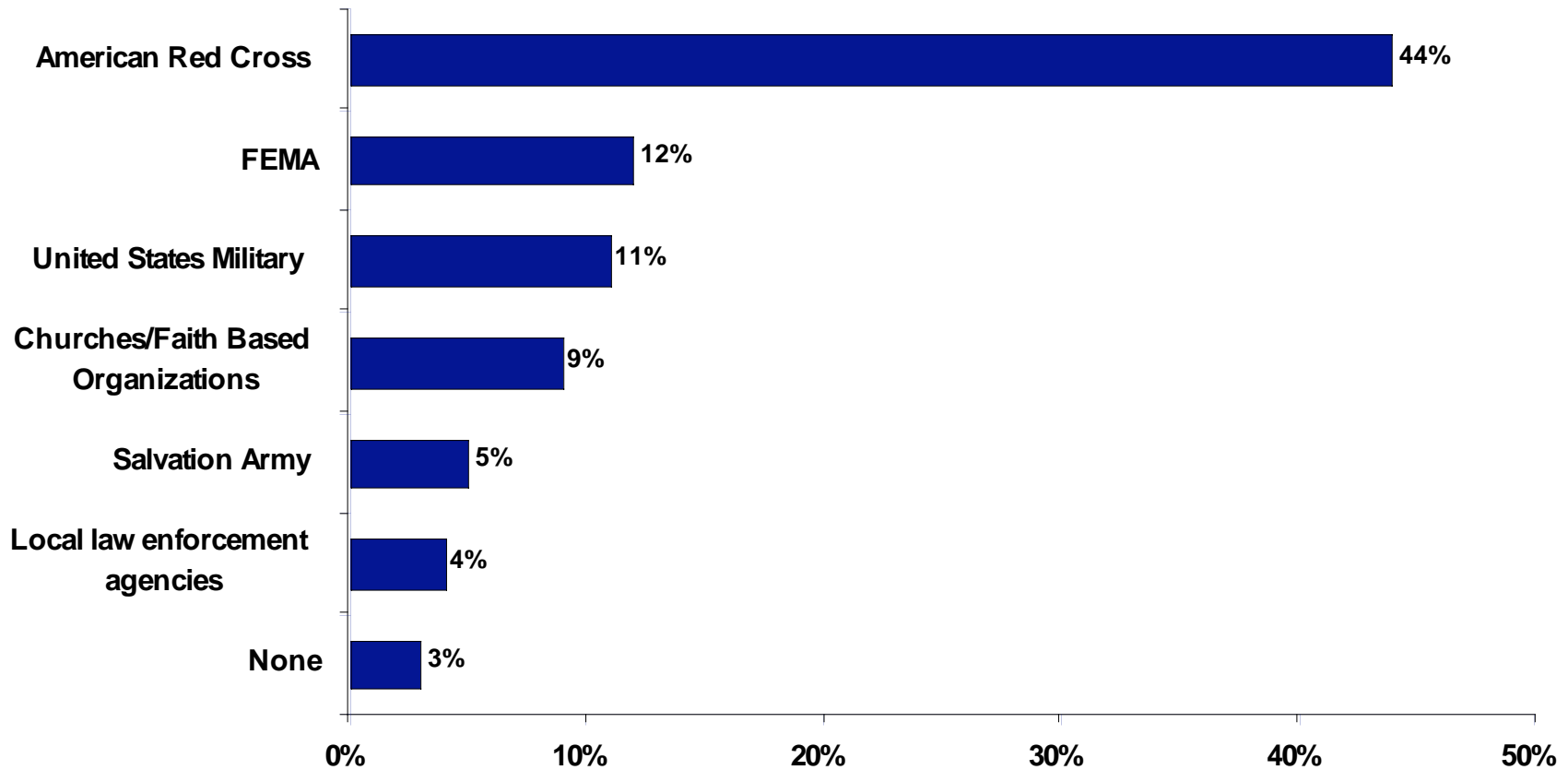

BASE: All respondents (n=1,089)

Why Best Overall Relief Organization

- § *They were so friendly, so kind, so polite, and generous with water, ice, MRE's, tarps, etc.*
- § *They went in and saved people--rescued them from the tops of houses. Appeared to have treated people with dignity. Seeing them in action brings a smile to a person's face.*
- § *They are the best organized national organization and they don't waste a lot of money on administrative costs. Faith based groups and local groups are also very good in this area.*
- § *I have my friends and my family and we spoke on this. We went through so much to even try and get anything from the other agencies. They were kind and they treated me with respect. I cried when I talked to them they seemed to care. I live by myself with my kids. They helped me try and put myself together.*
- § *They were everywhere that you went.*
- § *They did what they said they were going to do when they said they were going to do it.*
- § *They are the only ones that helped us when we needed it.*
- § *Because they were the most supportive and they would come by and they were more concerned. The other companies made it look like another day at work.*
- § *Very compassionate, always there, helpful.*

Evaluation of Relief Services

Why Best Overall Relief

Q832: Why do you say that?

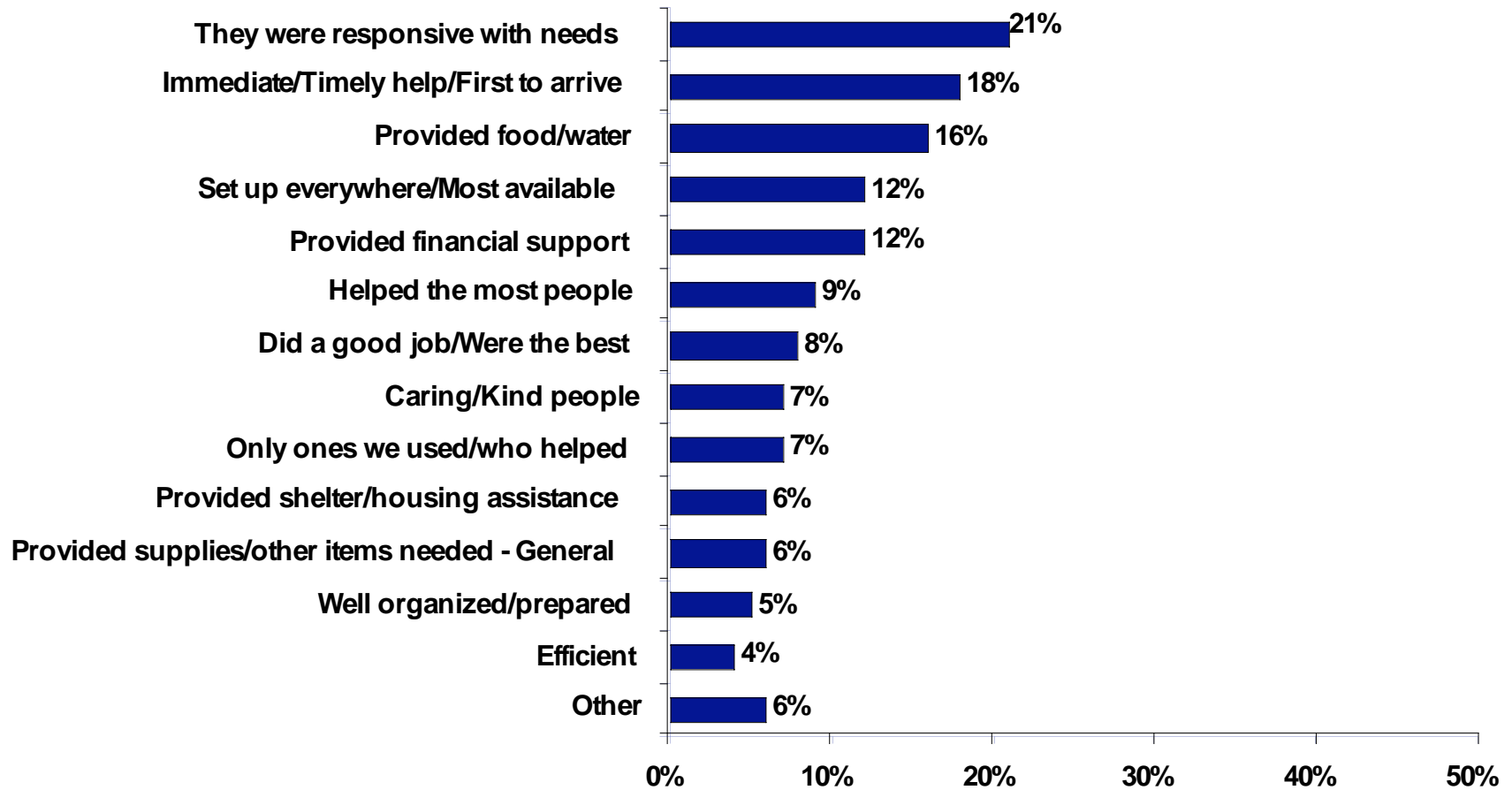

BASE: All respondents (n=1,089)

Evaluation of Relief Services

Organization Needing the Most Improvement

Q835: If you could single out one agency that could use the most improvement when providing relief, which one would it be?

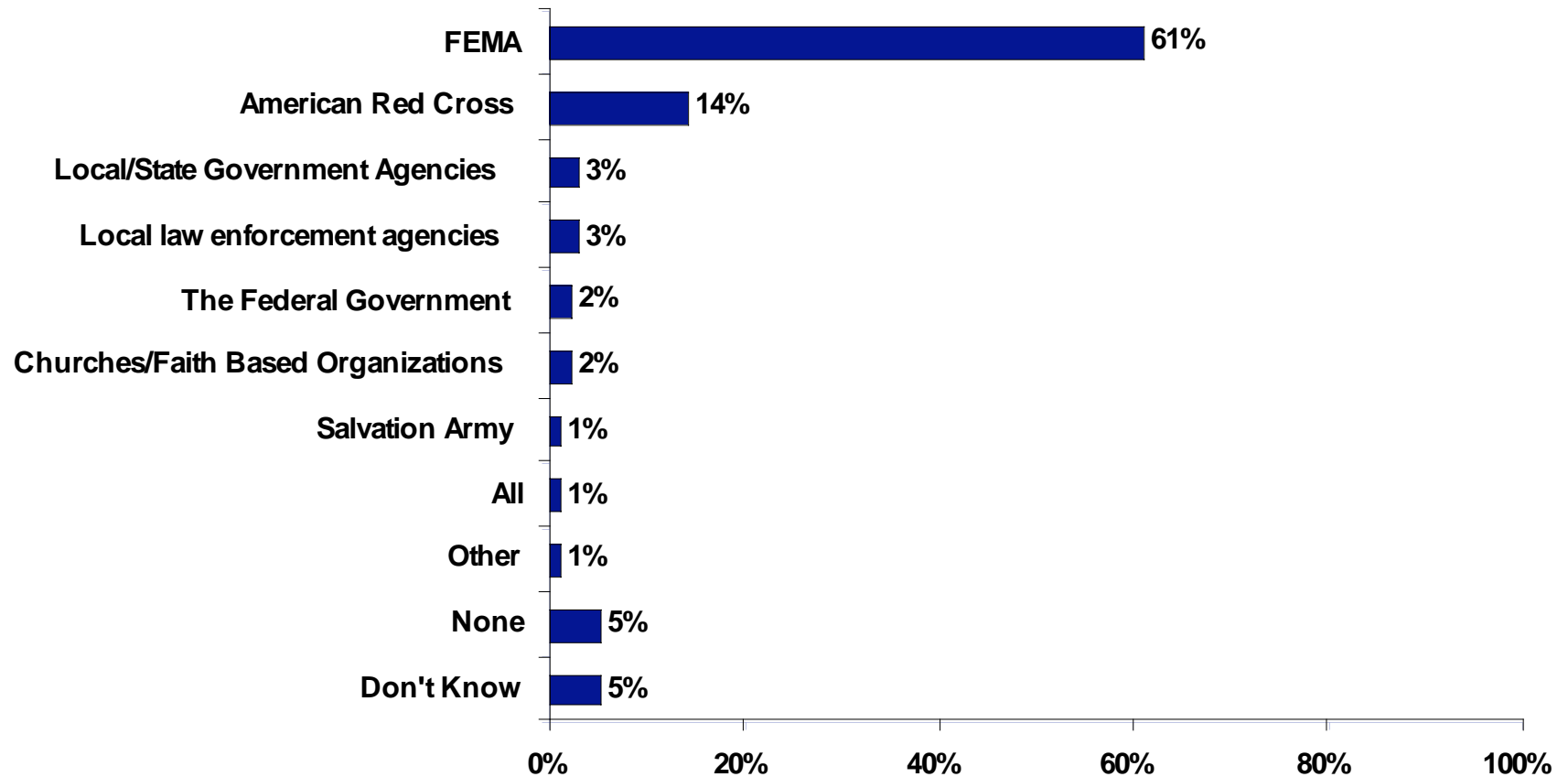

BASE: All respondents (n=1,089)

Why Organization Needs the Most Improvement

- § *For a group that is supposed to be prepared to handle emergencies, they were the most poorly organized I have ever seen.*
- § *They needed to be more organized, more efficient, with less lines and waits, which was hard on the elderly.*
- § *Can't get any answers from them.*
- § *Lack of communication to local personnel. Too much bureaucracy.*
- § *Too slow, too much bureaucracy, too much bs. not enough people that have a clue to poor people's plight, indifferent to calls for help, unorganized, planning off the cuff with no foresight.*
- § *They are hard to get through to and when you do get to them they are not helpful or compassionate. They should be understanding, and patient but they are not. If they cannot help you they should direct you to someone else but they cannot even do that. They do not know what they are doing.*
- § *I did not see the compassion, I did not see the urgency, I did not see an agency as large as this particular agency being effective in a way that peoples needs were being met. They did get some help out to people but it took so long. I just hate the way they did the red tape for the people who had lost family. If they could reduce the red tape that would have helped. There were people that needed help. I did not see and hear the communication.*

Evaluation of Relief Services

Why Organization Needs the Most Improvement

Q837: Why do you say that?

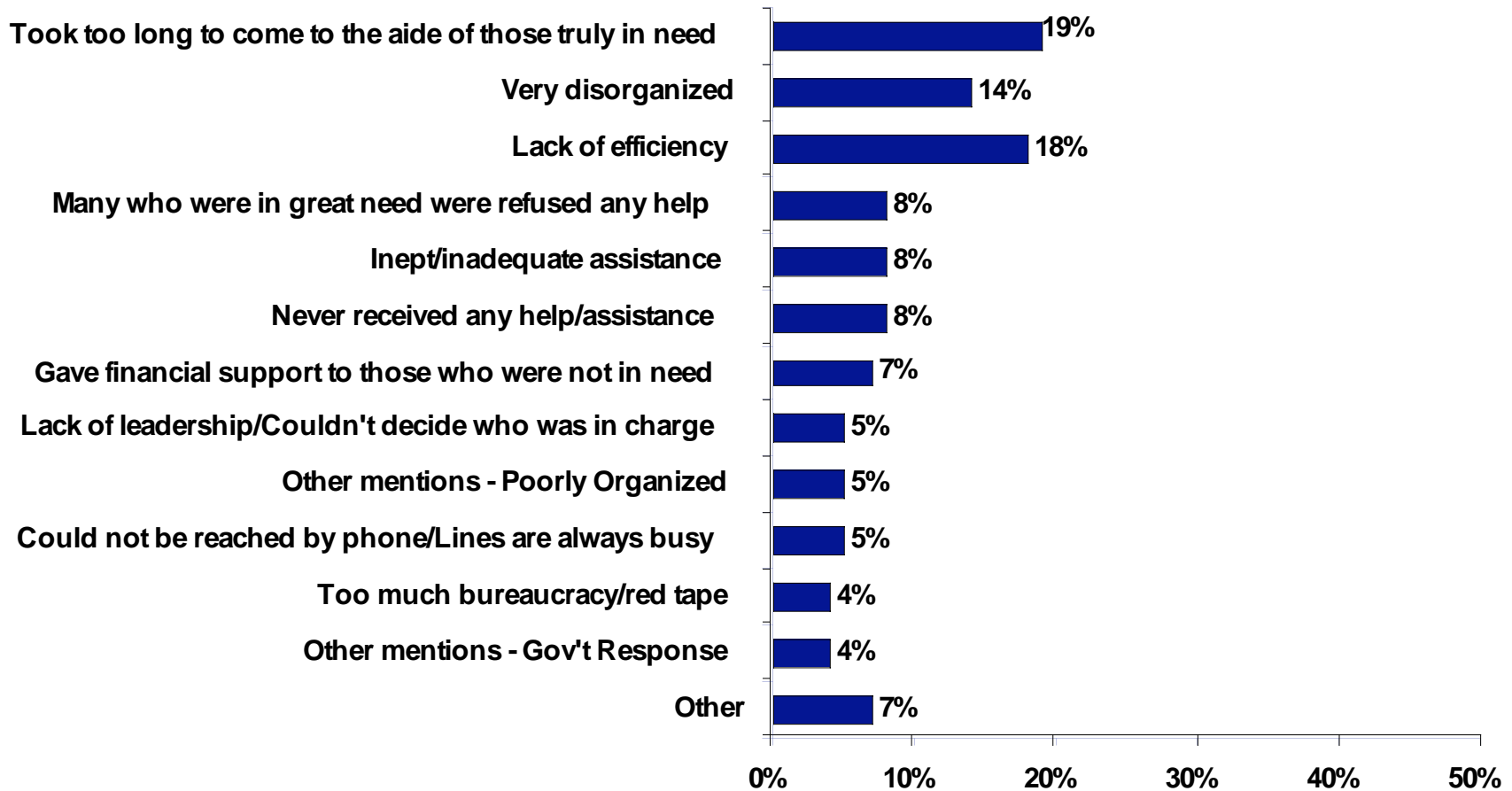

BASE: All respondents (n=1,089)

Storm Aftermath

Current Residence of Those Affected by Katrina

Q410: In what state are you currently residing?

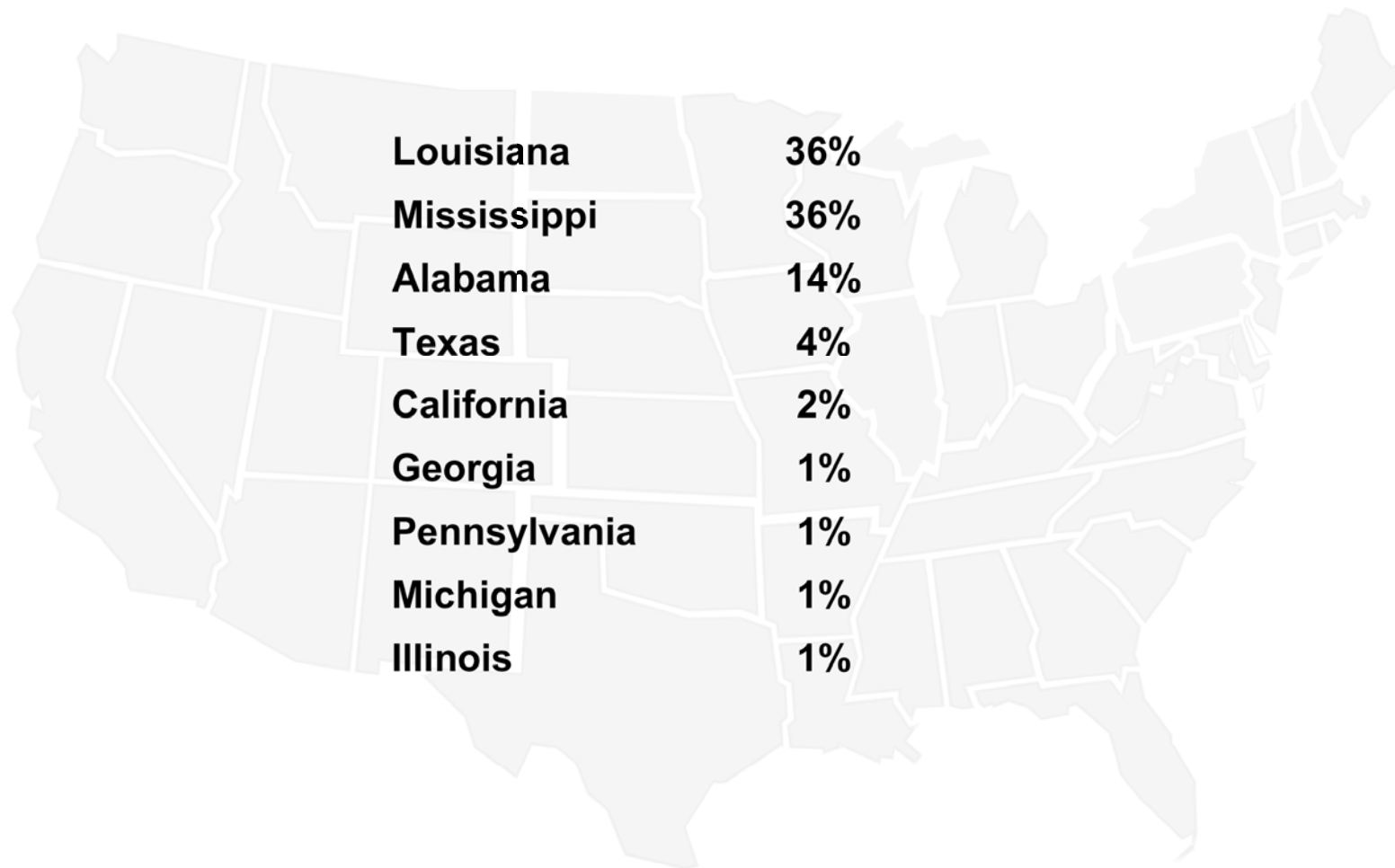

BASE: All respondents (n=1,089)

Current Residence

Q415: Where are you currently residing?

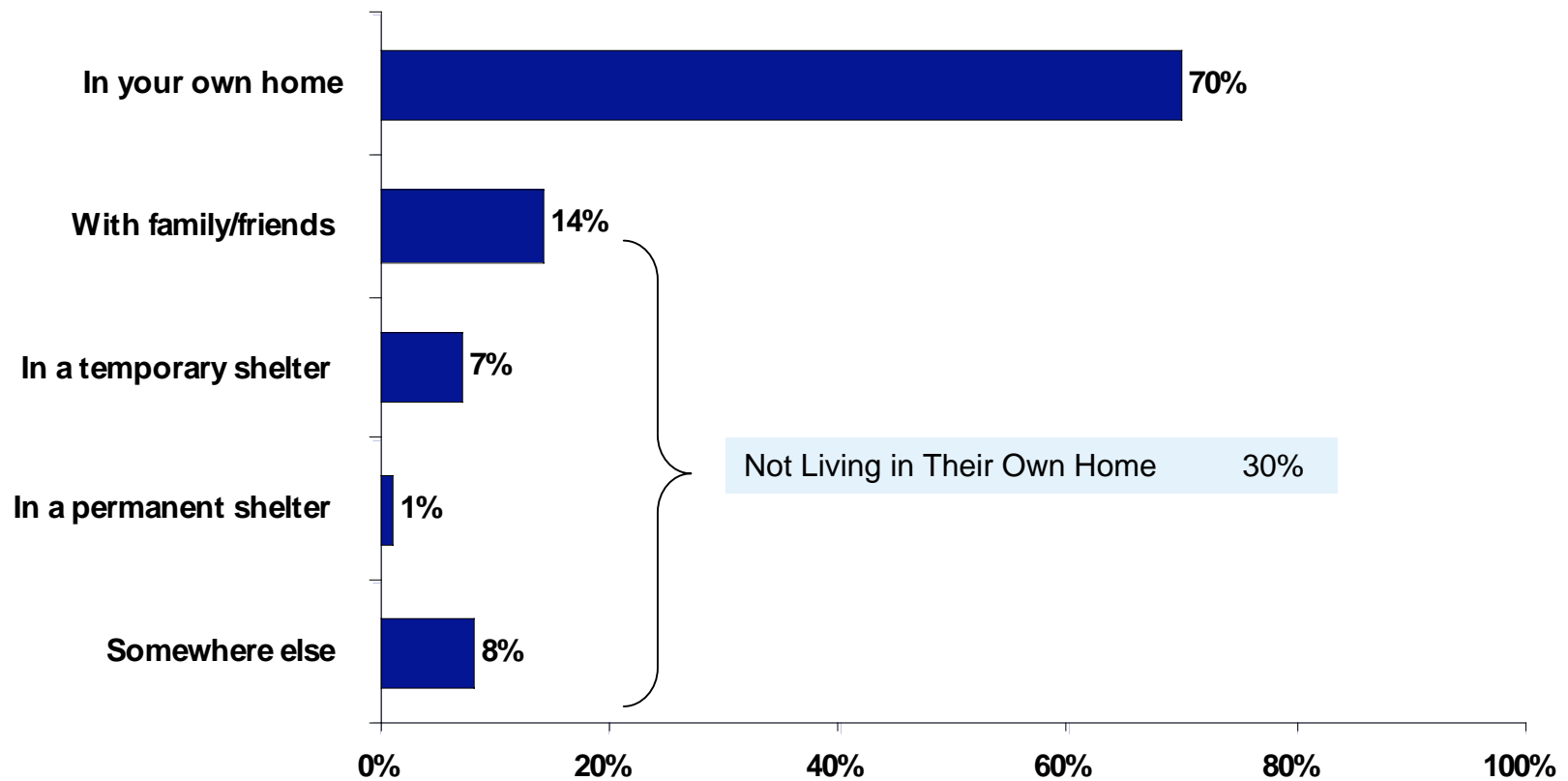

BASE: All respondents (n=1,089)

Future Residency Plans

Q910: Do you plan on staying for the long term in the same state/area in which you are currently living, or are you there only temporarily until you can go back home?

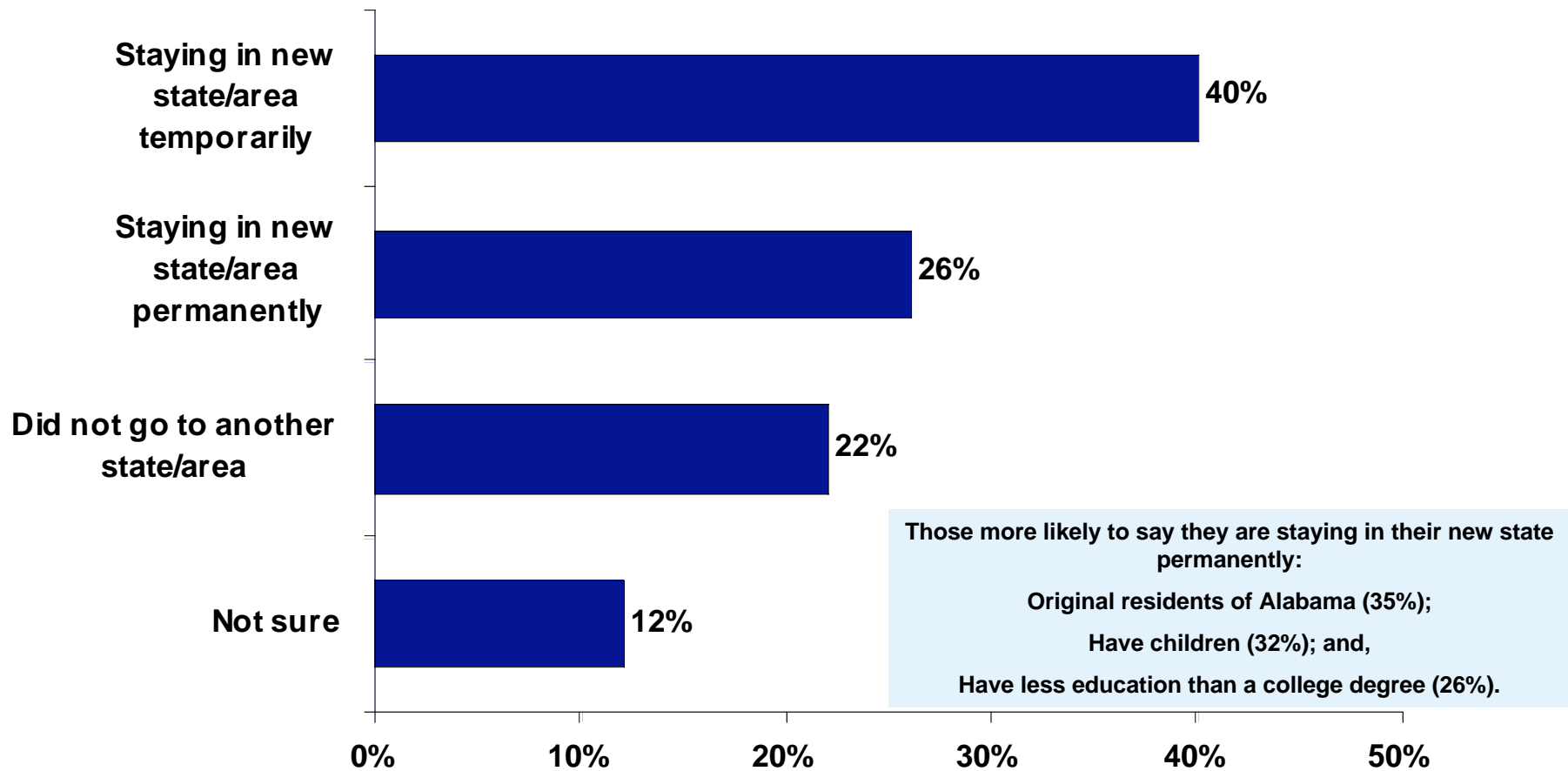

BASE: All respondents (n=1,089)

Road to Recovery

Q850: How strongly do you agree or disagree with the following statements?

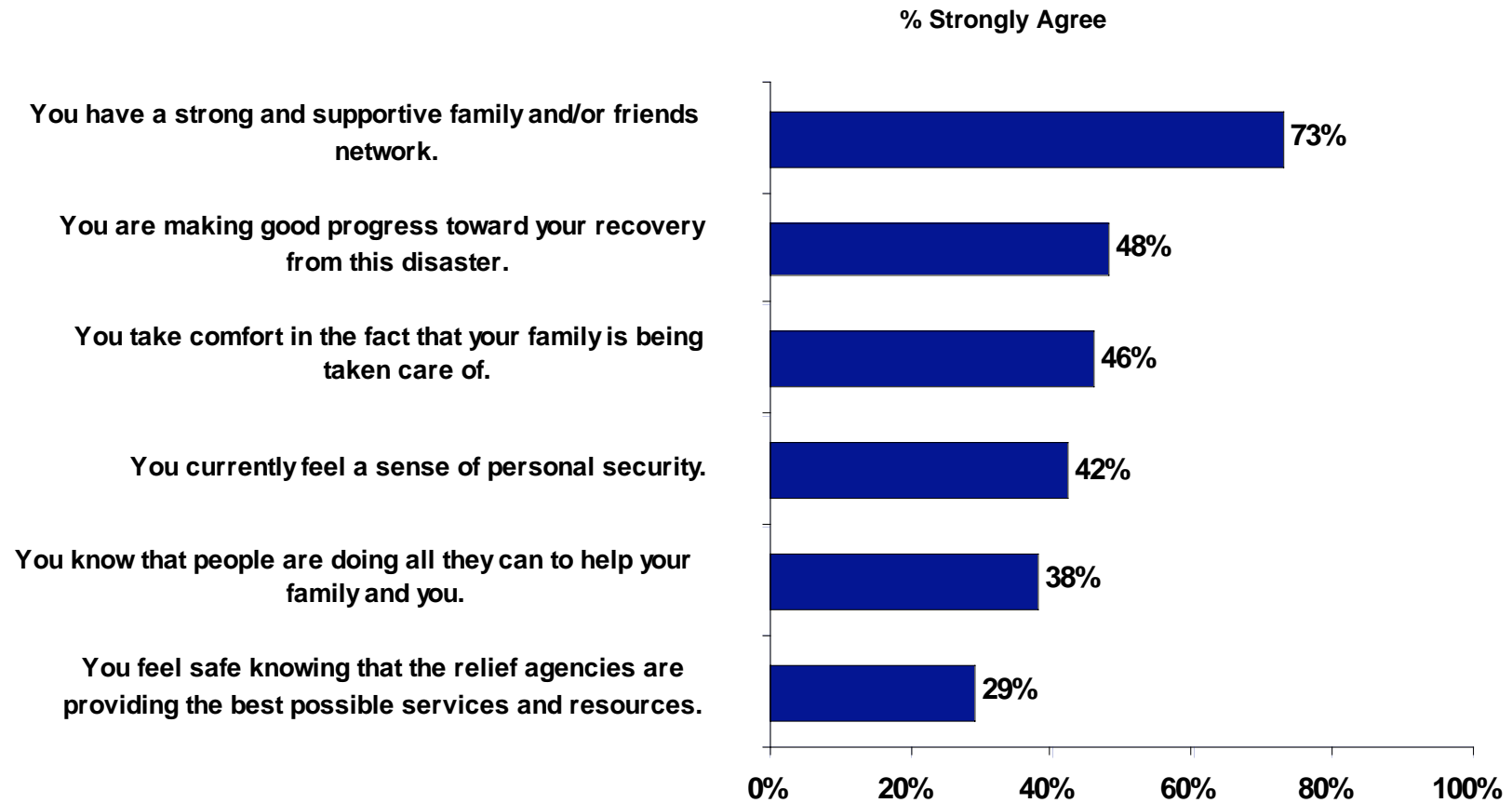

BASE: All respondents (n=1,089)

Road to Recovery

A Closer Look at Recovery by State

Q850: How strongly do you agree or disagree with the following statements?

% Strongly Agree

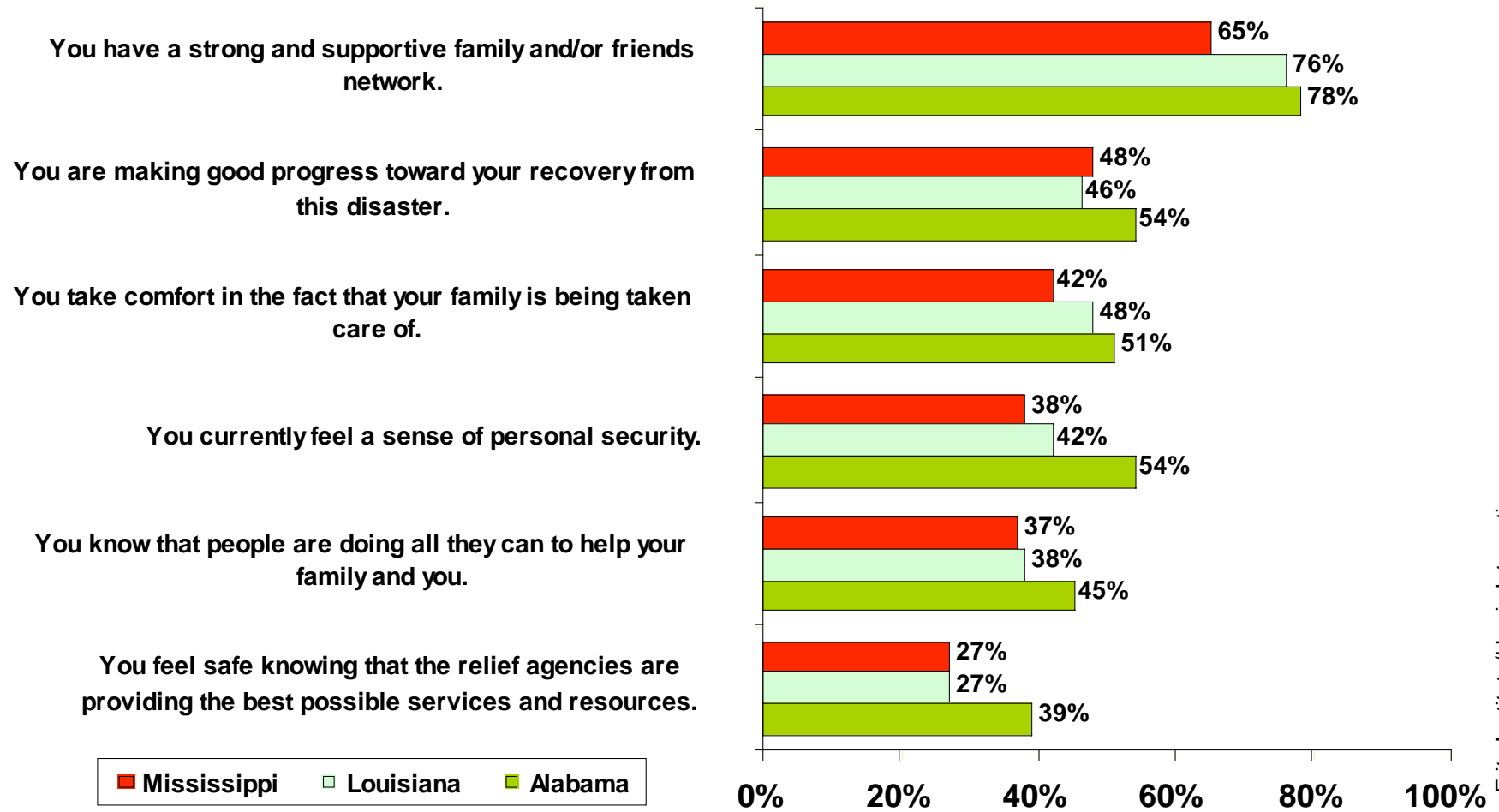

BASE: Mississippi (n=329); Louisiana (n=566); Alabama (n=194)

Since the hurricane, what experiences stand out in your mind?

- § *People pulling together. Each family reaching out for each other. I am concerned about now. Do we, as people, get out there together and prepare ourselves for the next storm or hurricane? We need to prepare to get nonperishable items and prepare for what is to come next. This is my concern because of what Katrina has done and there can be much more that can happen.*
- § *The way FEMA is treating the people. Some people that did not need money got it and others who really needed money did not get it. I know some people are still sleeping in pup tents. These are human beings, and they work hard for what they have. It was destroyed in the storm. FEMA was only giving out \$300 some dollars. Those people are living in a pup tent as of this day.*
- § *Being depressed. Not knowing where to go. Just unhappy. It is a frightening time.*
- § *How we are going to recover and if it is ever going to get better. Our insurance is not wanting to pay. A lot of the stuff came out of our own pocket.*
- § *So many people dying stands out in my mind. I can not ever forget that. It stands out in my mind because seeing all those little children. Every time I close my eyes, I see people drowning. I see them standing on the roof. I can not forget that.*
- § *Wondering if I will survive this financially and if my kids and grandkids will have a place. I was not too worried about myself just my kids.*
- § *Not a home to go to. I feel helpless.*

Aftermath of Katrina

Recollection of Experiences

Q1615: Since the hurricane, what experiences stand out in your mind?

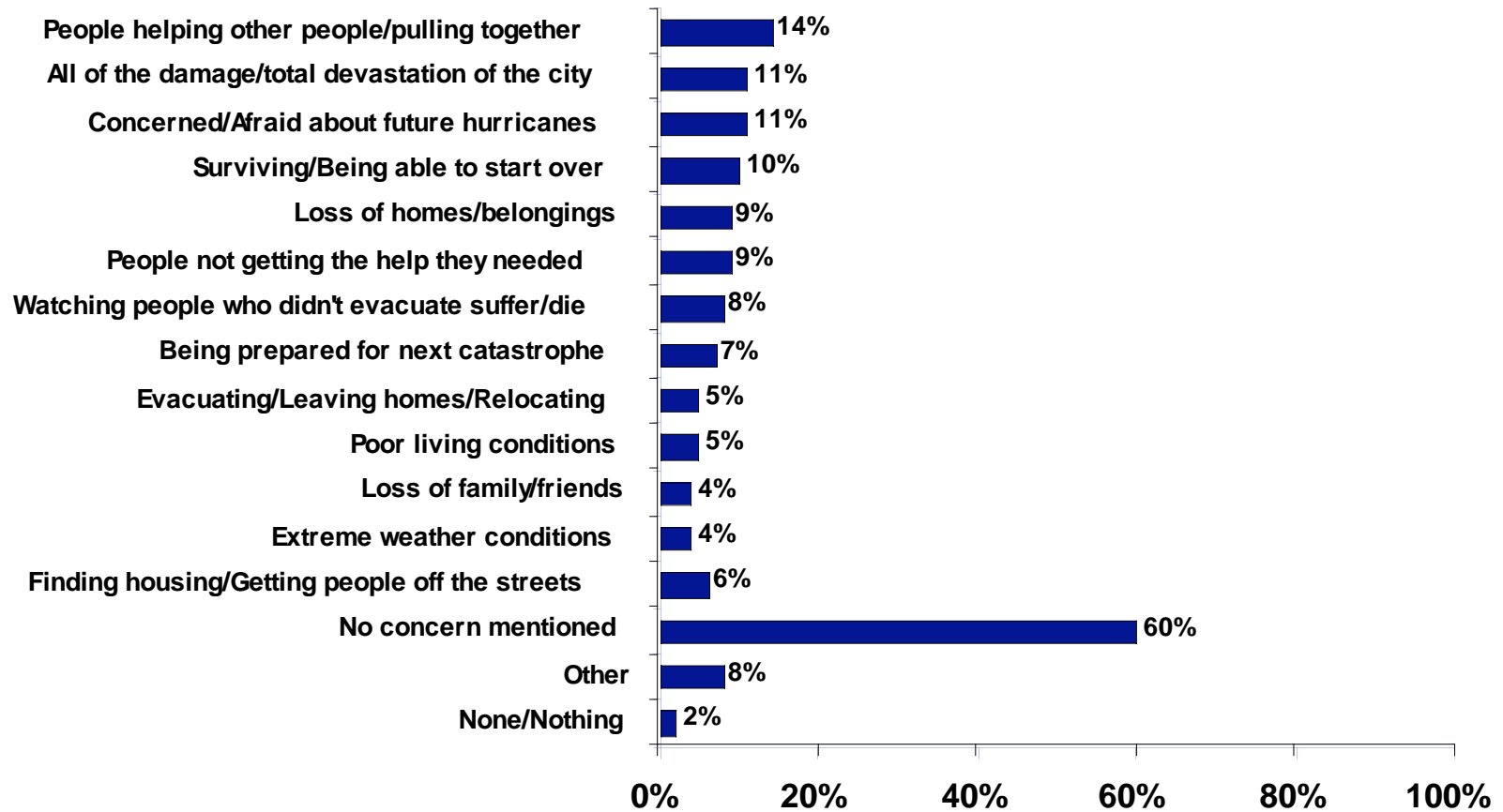

BASE: Telephone and in-person respondents (n=404)

Based on what you have been through, what are your concerns for the future?

- § *Major lifestyle adjustments having to start over.*
- § *To get over the depression that I am going through and get a job and get on with my life.*
- § *To find permanent housing.*
- § *Getting back to my family.*
- § *Being prepared for the next storm.*
- § *My concerns are that the state and locale government work closer together to do a better job evacuating people. After a disaster they work better together without partisan disagreement and local state and government fighting.*
- § *My concerns for the future are to rebuild the Gulf Coast and getting our economy back on track. Everybody left, that is why I am concerned.*
- § *Not knowing what the future holds.*

Aftermath of Katrina

Concerns for the Future

Q1620: Based on what you have been through, what are your concerns for the future?

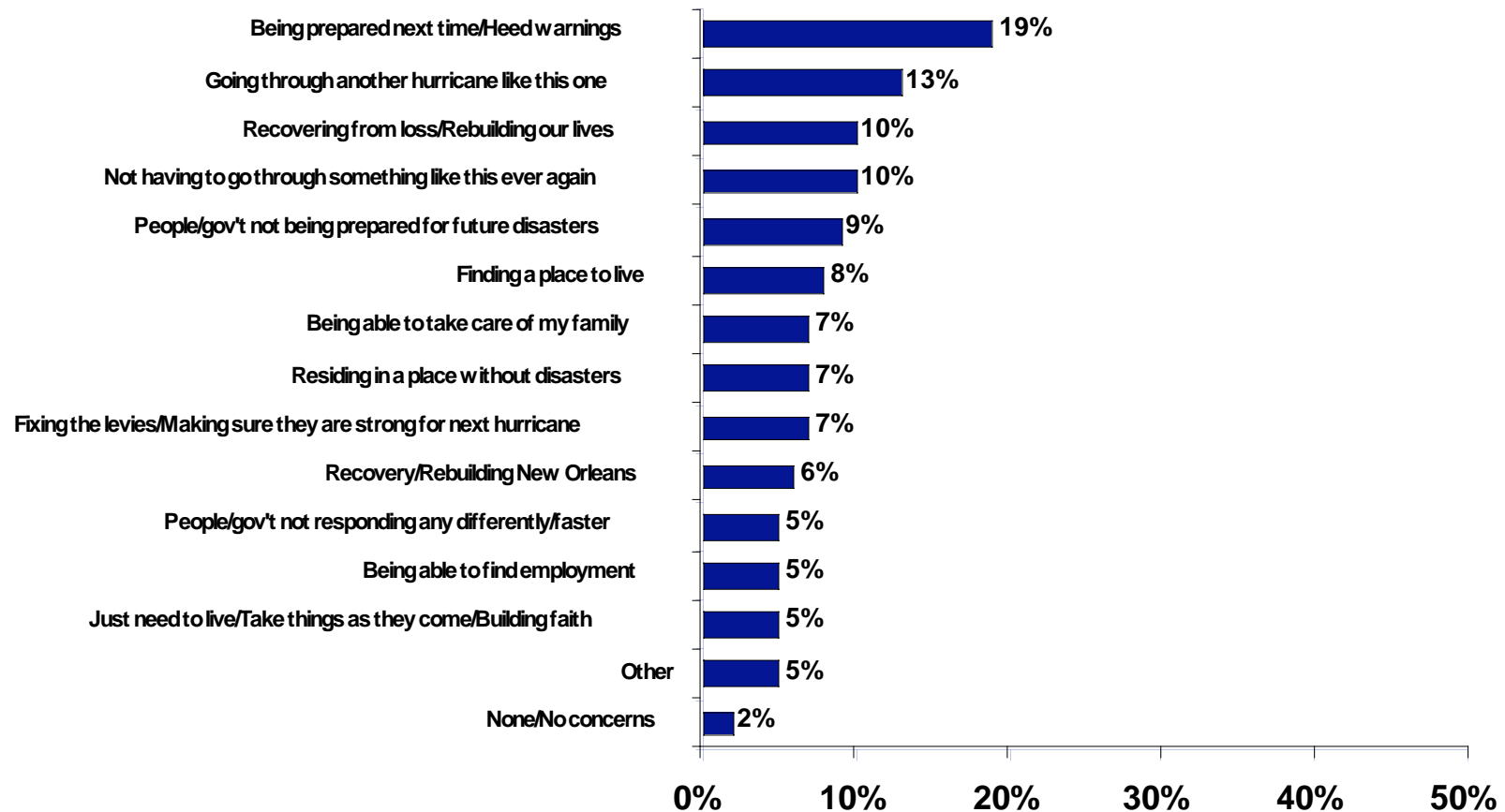

BASE: Telephone and in-person respondents (n=404)

Methodology

- This Fritz Institute Hurricane Katrina survey was conducted online, by telephone and in person by Harris Interactive among a total of 1,089 adults affected by Hurricane Katrina.
- Interviews were conducted between November 3-14, 2005 and January 13-26, 2006.
- A total of 685 interviews were conducted online.
 - Zip codes were matched up to those within Harris Interactive online panel member database and email invitations were sent to a sample of people in areas affected by Hurricane Katrina.
 - Figures for the online results only were weighted for age, sex, race/ethnicity, education, region and household income where necessary to bring them into line with their actual proportions in the population. Propensity score weighting was also used to adjust for online respondents' propensity to be online.
- A total of 297 interviews were conducted by telephone.
 - The American Red Cross and the Salvation Army provided lists of service recipients with current phone numbers and addresses for the recipients. These respondents were contacted by one of Harris' highly experienced interviewers.
- A total of 107 interviews were conducted in person.
 - Those affected by Katrina, originally residing in Louisiana, Mississippi or Alabama, were Intercepted by one of Harris' highly experienced field interviewers.
- All surveys are subject to several sources of error. These include: sampling error (because only a sample of a population is interviewed); measurement error due to question wording and/or question order, deliberately or unintentionally inaccurate responses, nonresponse (including refusals), interviewer effects (when live interviewers are used) and weighting.
- With one exception (sampling error) the magnitude of the errors that result cannot be estimated. There is, therefore, no way to calculate a finite "margin of error" for any survey and the use of these words should be avoided.

Profile of Survey Participants

Initial State of Residence

Q405: In what state were you living during Hurricane Katrina?

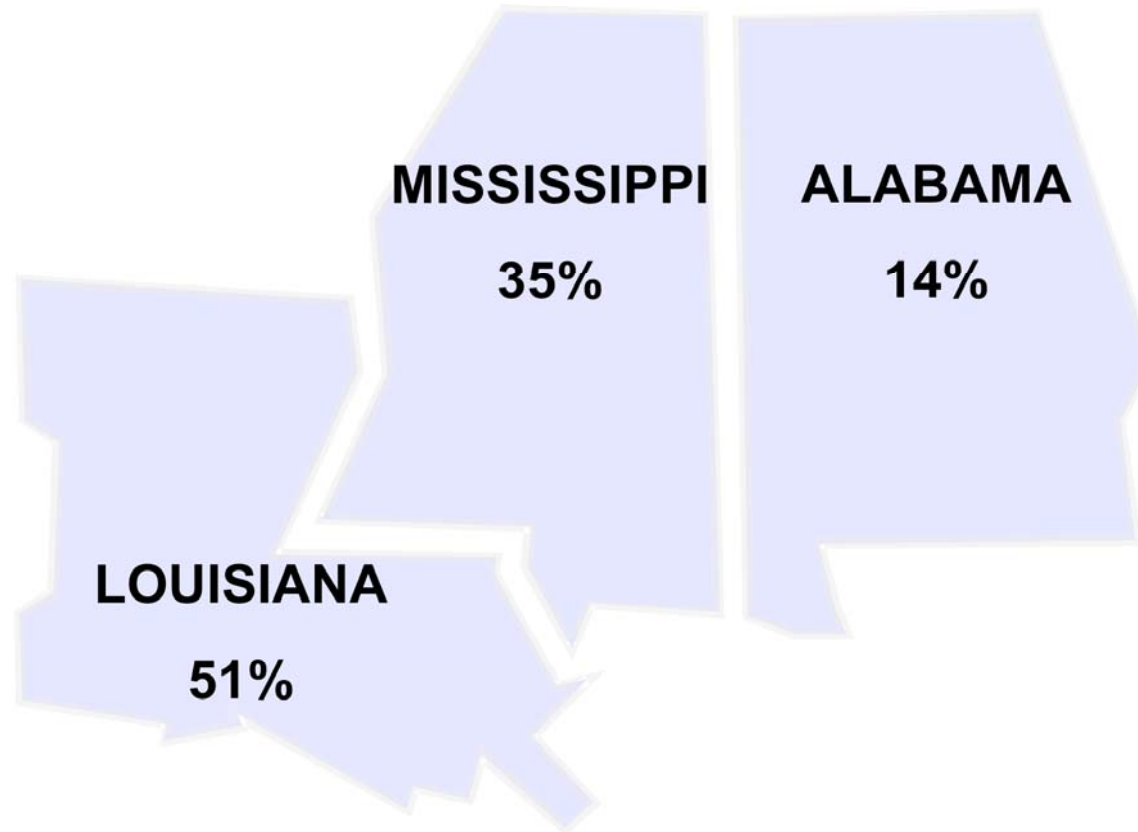

BASE: All respondents (n=1,089)

Victims with Disabilities

Q1000: Do you have any physical disabilities/special needs?

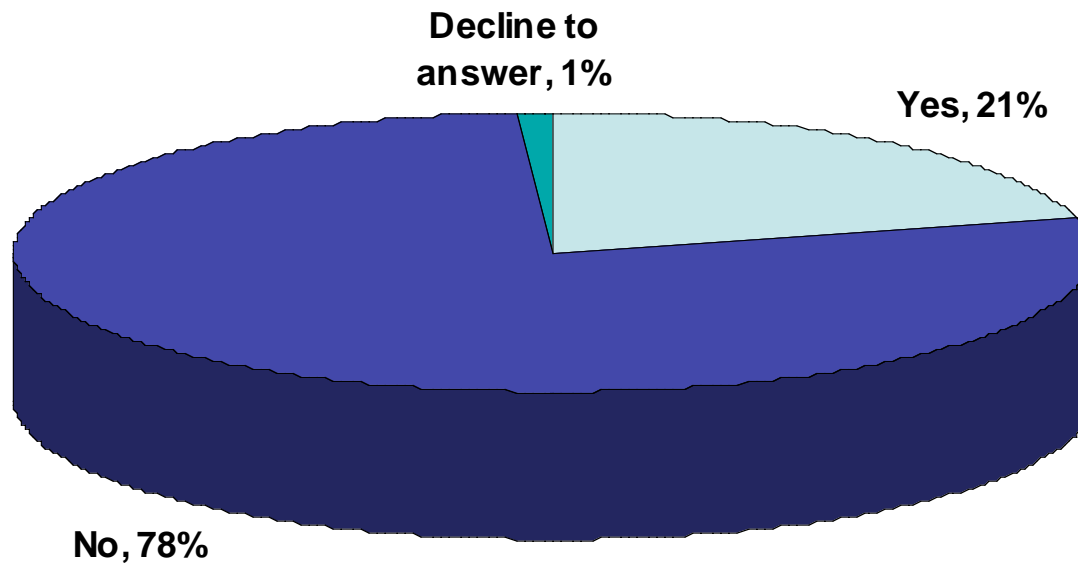

BASE: All respondents (n=1,089)

Type of Residence Before Katrina

Q1005: Where did you live before Hurricane Katrina struck?



**SINGLE FAMILY
HOME**

79%



**MULTI-FAMILY
HOME**

20%

BASE: All respondents (n=1,089)

Pet Ownership

Q1010: Do you, or did you, own any pets?

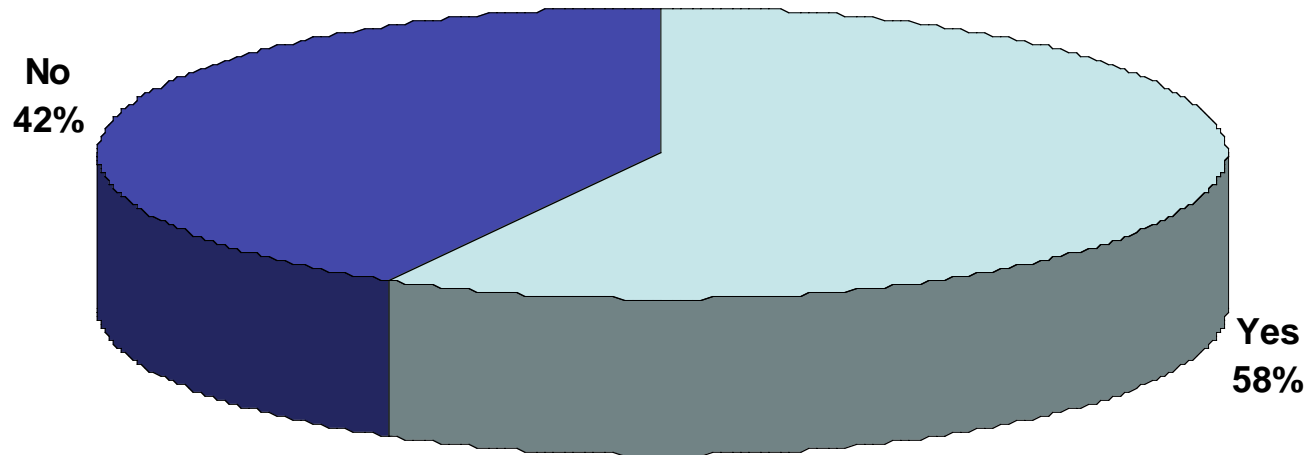

BASE: All respondents (n=1,089)

Marital Status

Q202: What is your marital status?

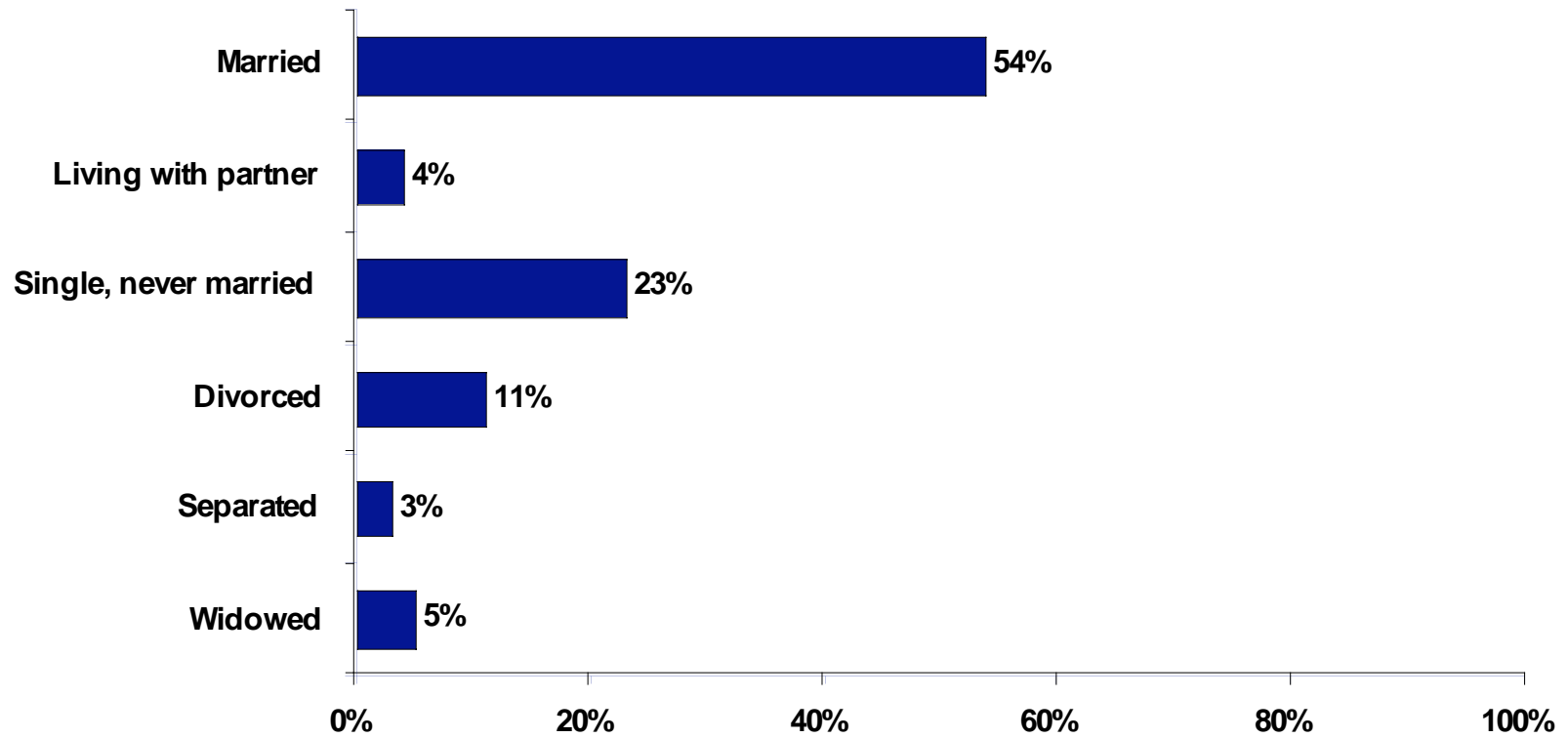

BASE: All respondents (n=1,089)

Children in Household

Q206: How many children under the age of 18 live in your household?

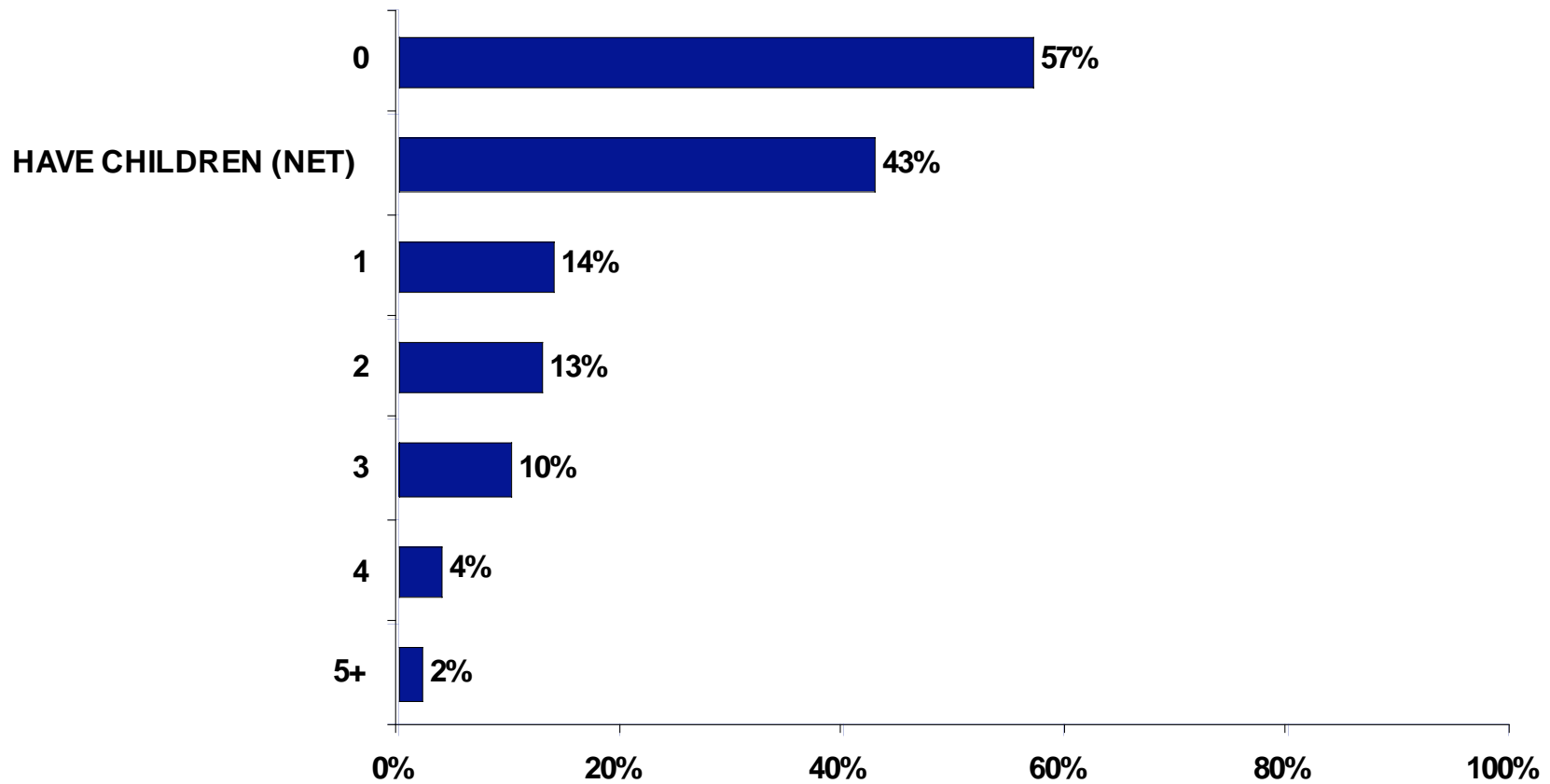

BASE: All respondents (n=1,089)

Employment Status

Q210: What is your employment status?

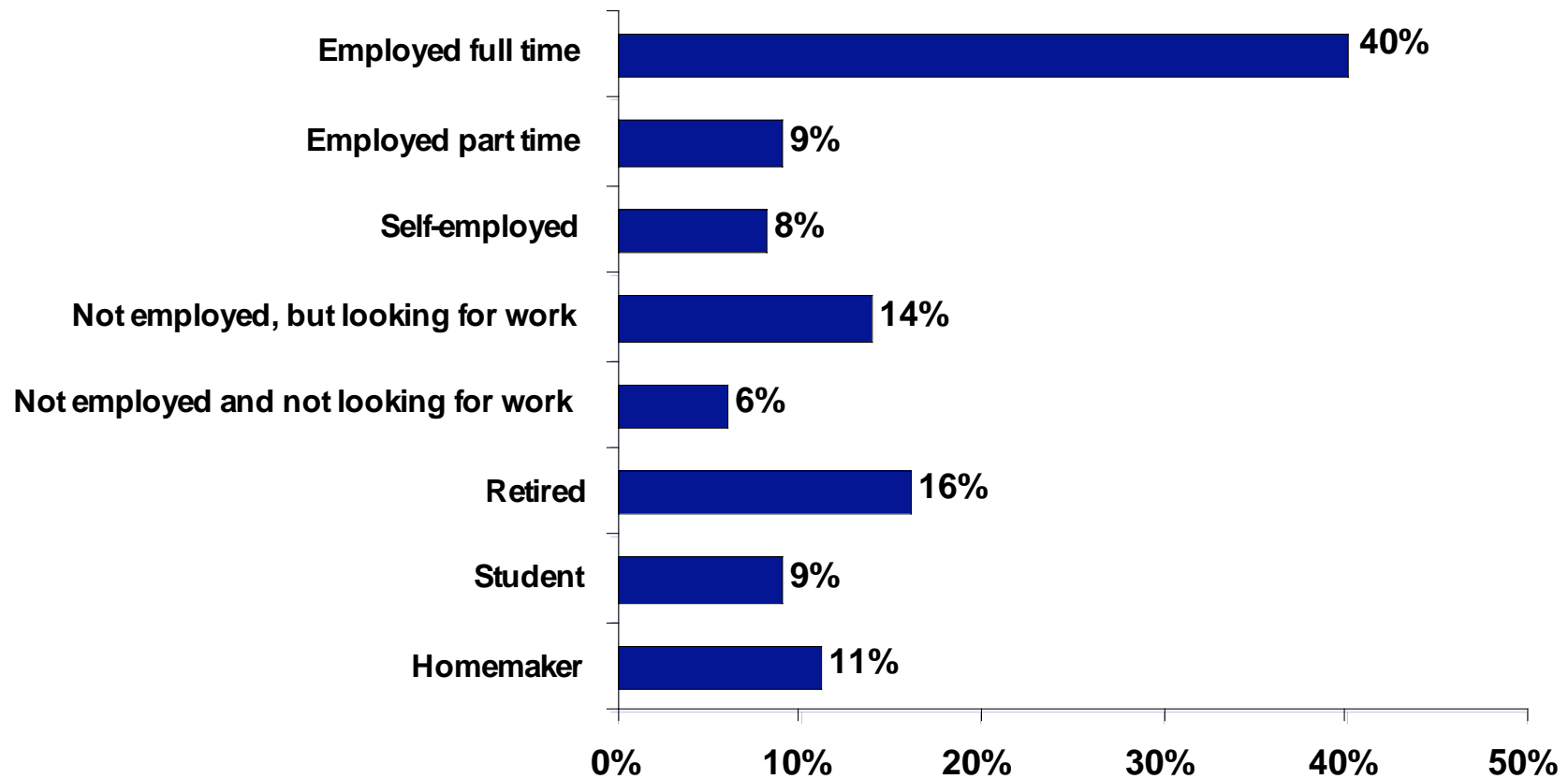

BASE: All respondents (n=1,089)

Level of Education

Q216: What is the highest level of education you have completed or the highest degree you have received?

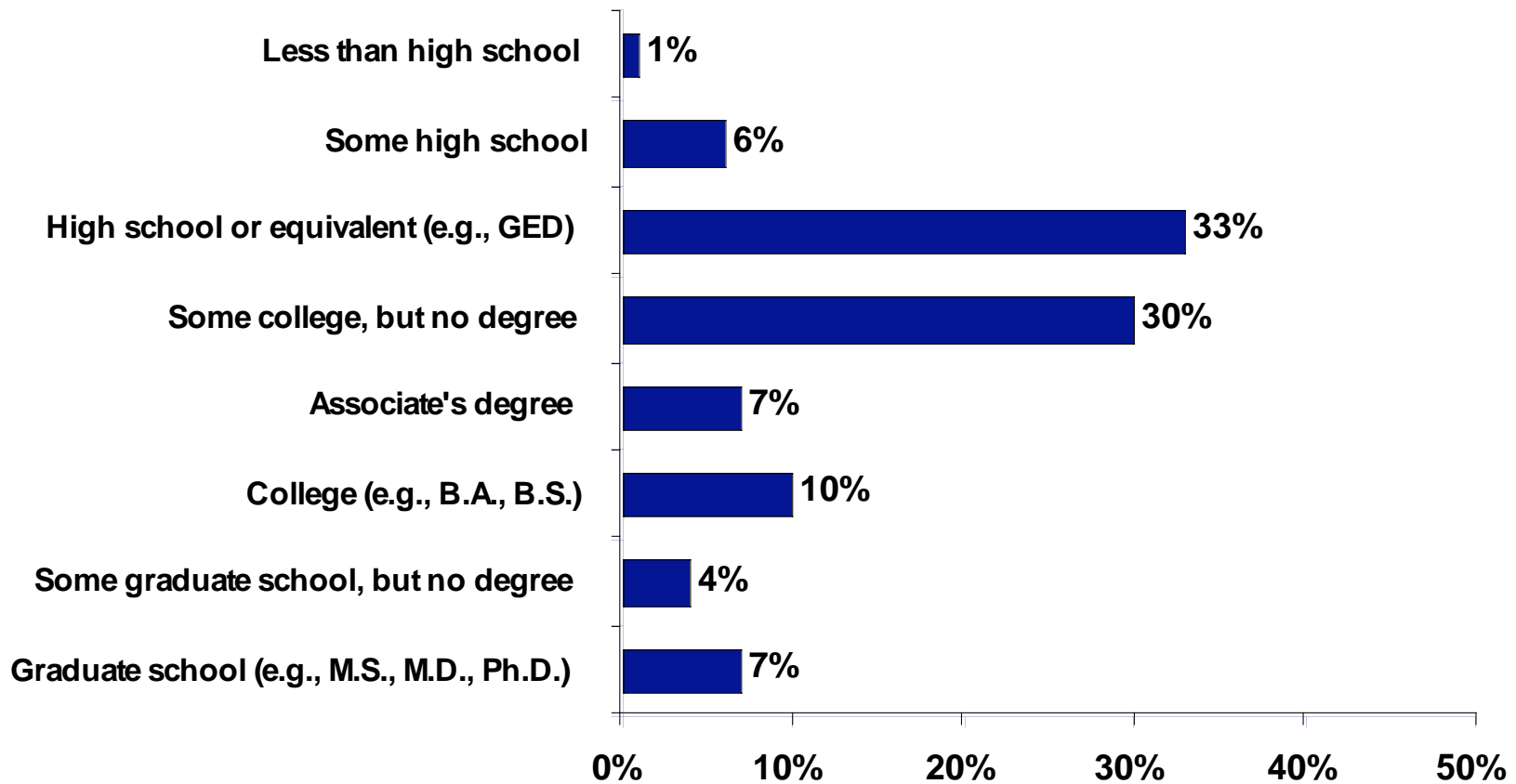

BASE: All respondents (n=1,089)

Household Income

Q232: Which of the following income categories best describes your total 2004 household income before taxes?

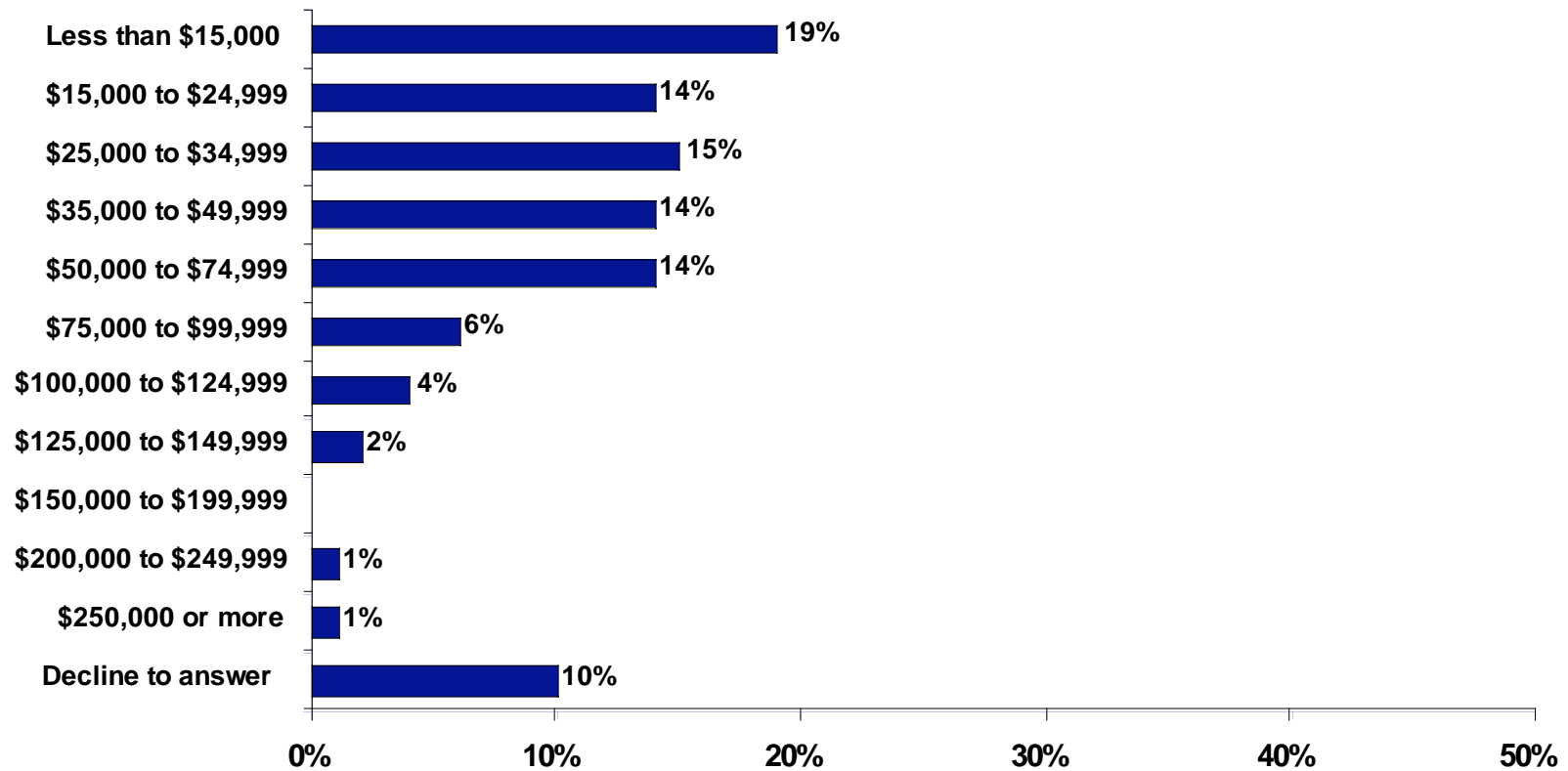

BASE: All respondents (n=1,089)

Ethnicity

Q1055: Do you consider yourself...?

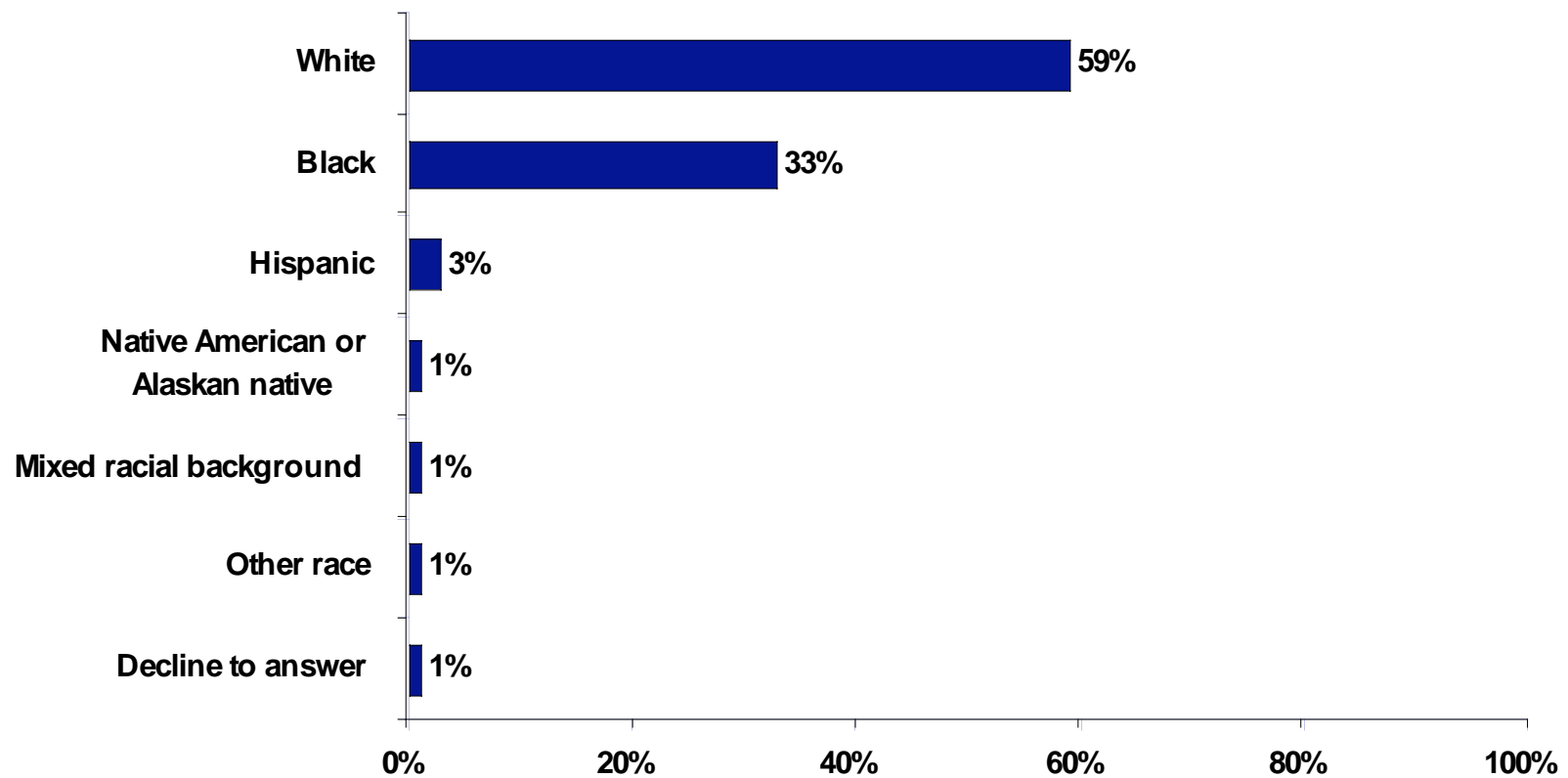

BASE: All respondents (n=1,089)